

### HPV22M SERIES – HIGH PRESSURE HIGH SPEED DOUBLE PUMPS

These double pumps consist of two HPV2 series single pumps combined in tandem within a single housing and driven by a common shaft. Fluid delivered from the two-separate ports can be either supplied to separate or common circuits. These HPV pumps are designed for high-pressure functions. Suitable for mobile applications like Drill rigs, Railways & Construction Equipments.

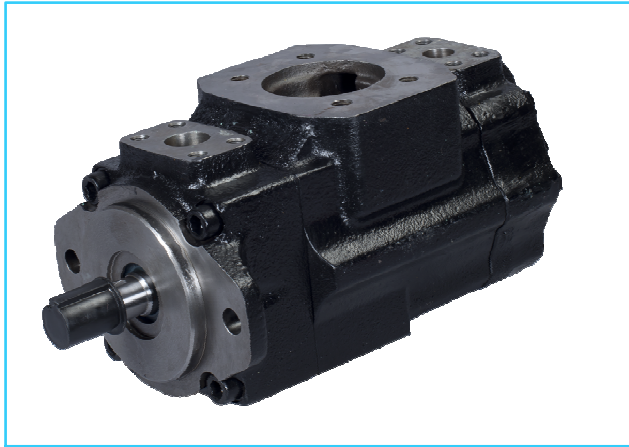

Graphic Symbol

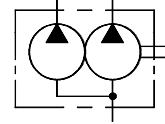

### Specifications

Model Number	Series	Geometric Displacement cm <sup>3</sup> /rev.		Max. Oper. Pressure Kgf/cm <sup>2</sup>	Output Flow and Input Power	Shaft Speed Range r/min.		Mass (Approx.) Kg.	
		1 <sup>st</sup> Section	2 <sup>nd</sup> Section			Max.	Min.	Flange Mounting	Foot Mounting
HPV22M	03	10.8	10.8	280	Ref. Page Nos. 220, 221, 222 & 223	2800	400	26.0	29.3
	05	17.2	17.2						
	06	21.3	21.3						
	08	26.4	26.4						
	10	34.1	34.1						
	12	37.1	37.1						
	14	46.0	46.0						
	15	50.5	50.5						
	17	58.3	58.3						
	20	63.8	63.8						
	22	70.3	70.3						
	25	79.3	79.3						
	28	88.8	88.8	210					
	31	100.0	100.0						

## Model Number Designation

HPV22M	-14	-12	-F	-R	A	A	A	-U0	-K1	-10
Model Number	Series		Type of Mounting	Direction of Rotation	1 <sup>st</sup> Section Discharge Port Position	2 <sup>nd</sup> Section Discharge Port Position	Suction Port Position	Mounting W/ Connection Variables	Type of Shaft	Design Number *
	1 <sup>st</sup> Section	2 <sup>nd</sup> Section								
HPV22M	03	03	<b>F:</b> Flange Mtg.  <b>L:</b> Foot Mtg.	<b>R:</b> Clockwise (Normal)  <b>L:</b> Anti-Clockwise				<b>U0, U1, U2, U3-</b> UNC port conn. (Refer table below)  <b>M0, M1, M2, M3-</b> Metric port conn. (Refer table below)	<b>K1-</b> Keyed (no SAE)  <b>S1-</b> Splined (SAE-B)  <b>S2-</b> Splined (SAE-BB)	10
	05	05								
	06	06								
	08	08								
	10	10								
	12	12								
	14	14								
	15	15								
	17	17								
	20	20								
	22	22								
	25	25								
	28	28								
31	31									

\* Design numbers subject to change from 10 to 19, but installation dimensions remain as shown.

\* For instructions regarding changing the port positions, consult YUKEN INDIA LTD.

### Mounting W / connection variables

Model Number	Mounting Type	1 <sup>st</sup> Discharge Port connection (D1)	2 <sup>nd</sup> Discharge Port connection (D2)	Suction Port connection (S)
HPV22M	U0	1"	1"	3"
	U1	1"	3/4" <sup>*1</sup>	3"
	U2	1"	1"	2 1/2" <sup>*2</sup>
	U3	1"	3/4" <sup>*1</sup>	2 1/2" <sup>*2</sup>
	M0	1"	1"	3"
	M1	1"	3/4" <sup>*1</sup>	3"
	M2	1"	1"	2 1/2" <sup>*2</sup>
	M3	1"	3/4" <sup>*1</sup>	2 1/2" <sup>*2</sup>

\*1 For 46 cm<sup>3</sup>/rev. max.

\*2 For 126 cm<sup>3</sup>/rev. max.

The larger cartridge should always be in 1<sup>st</sup> Section (when compared with Second Section).

## Cartridge Kit Model Number

### 1<sup>st</sup> Section Discharge Port

CHPV22M	-14	-D1	-R	-10
Model Number	Nominal Displacement	Discharge Port	Shaft Rotation	Design No.
	1 <sup>st</sup> Section			
CHPV22M	03	<b>D1:</b> 1 <sup>st</sup> Section Discharge Port	<b>R:</b> Clockwise (Normal)  <b>L:</b> Anti-Clockwise	10
	05			
	06			
	08			
	10			
	12			
	14			
	15			
	17			
	20			
	22			
	25			
	28			
31				

### 2<sup>nd</sup> Section Discharge Port

CHPV22M	-14	-D2	-R	-10
Model Number	Nominal Displacement	Discharge Port	Shaft Rotation	Design No.
	2 <sup>nd</sup> Section			
CHPV22M	03	<b>D2:</b> 2 <sup>nd</sup> Section Discharge Port	<b>R:</b> Clockwise (Normal)  <b>L:</b> Anti-Clockwise	10
	05			
	06			
	08			
	10			
	12			
	14			
	15			
	17			
	20			
	22			
	25			
	28			
31				

\* For instructions regarding replacing cartridge kit, consult YUKEN INDIA LTD.

## Hydraulic Fluids

- Suction Pressure**  
 Suction line pressure limit  $-0.20\text{Kgf/cm}^2$  to  $+0.30\text{Kgf/cm}^2$
- Cleanliness**  
 Contamination level should be within NAS class 9. Use of  $100\mu\text{m}$ (150 mesh) tank filter on suction side, 50mm above the tank bottom surface.
- Alignment of Shaft**  
 Employ a flexible coupling whenever possible & avoid stress from bending or thrust. Maximum permissible misalignment is less than  $0.1\text{mm}$ (0.004Inches) TIR & maximum permissible misangular is less than  $0.2^\circ$ .

## Instructions

- Precautions at starting**  
 At an initial operation or at an operation after a long rest, the pump may have difficulty in sucking up fluids. In such cases, an air bleed valve should be installed before hand in the discharge side (Model No.ST1001-※-10※), or discharge air by slightly slackening the connection on the discharge side. At starting, operate the pump intermittently as far as possible with no load.
- Other Precautions**  
 If a pump is used at speed below 1200 r/min, install the pump with the suction port upside so that the pump can suck up fluid easily at starting.

## Spare Parts List

### List of Seals

Sl. No.	Name of Part	Part Number	Qty.
1	O-Ring	PKH4-0205	2
2	O-Ring	PKH4-0206	2
3	O-Ring	PKH4-0207	1
4	O-Ring	PKH4-0211	1
5	Backup-Ring	PKH4-0184	2
6	Oil Seal (NOK)	25.4x38.1x6.35	1

Note : When ordering the seals, please specify the seal kit number KS-HPV22-10.

## Foot Mounting Parts

Sl. No.	Name of Part	Part Number	Qty.
1	Mounting Bracket	PK2-10513-8	1
2	Socket Head Cap Screw	M12 x 35Lg.	2
3	Spring Washer	WS-A-12	2

Note : When ordering the Foot Mounting Parts, please specify the Kit number HPV22-L-10.

HPV22M-\*\*-\*\*-\*\*-\*\*-\*-\*\*-\*-\*\*-\*-10

DIMENSIONS IN MILLIMETRES

● Flange Mounting

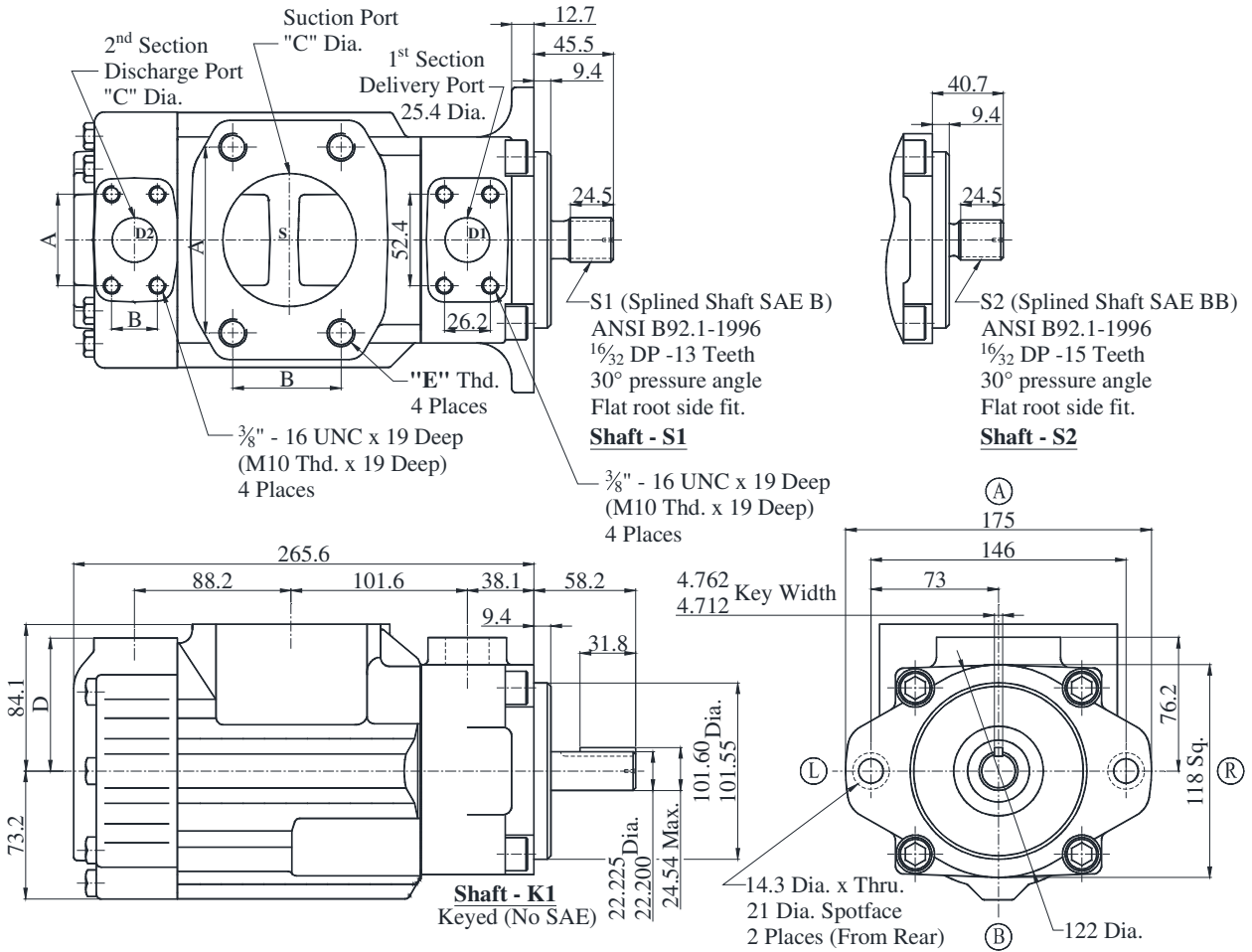

Port	Port Connection	Port Size	A	B	C	D	E Thd.
S	U0,U1,M0,M1	3"	106.4	61.9	76.2	-	5/8 – 11 UNCx28.4 Deep (M16x28.4 Deep)
	U2,U3,M2,M3	2-1/2"	88.9	50.8	63.5	-	1/2 – 13 UNCx24.0 Deep (M12x24.0 Deep)
D2	U0,U2,M0,M2	1"	52.4	26.2	25.4	74.7	3/8 – 16 UNCx19.0 Deep (M10x19.0 Deep)
	U1,U3,M1,M3	3/4"	47.6	22.2	19.0	76.2	3/8 – 16 UNCx19.0 Deep (M10x19.0 Deep)

● Foot Mounting

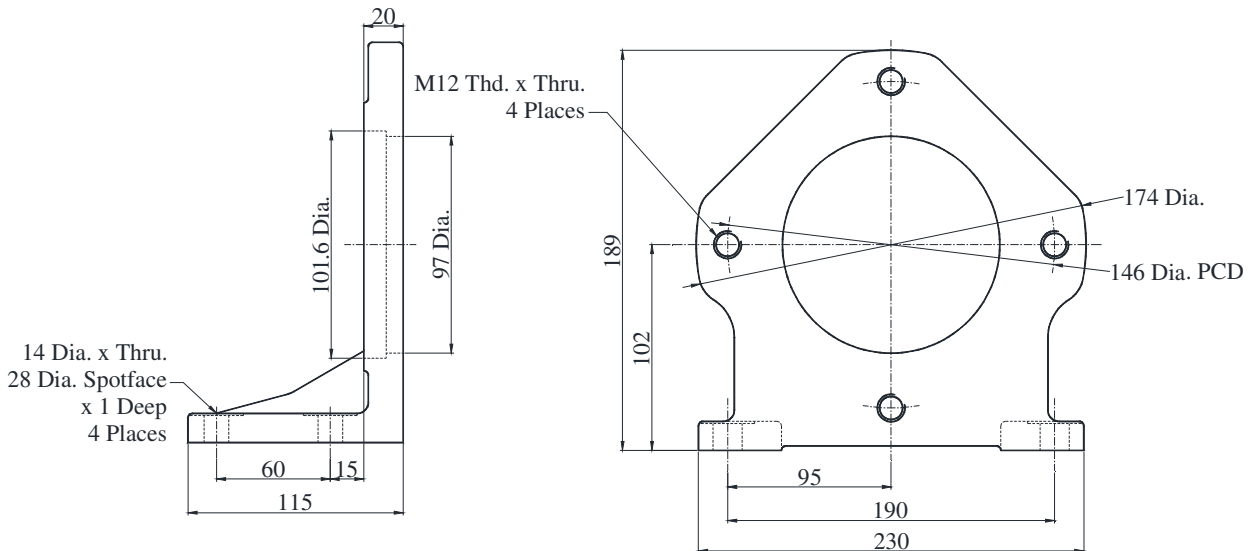

## Flanges

### Threaded Type

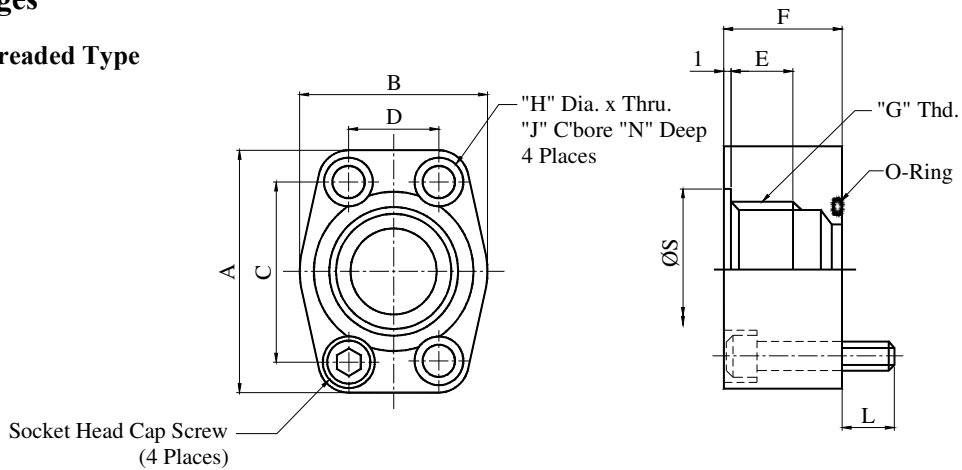

Kit Numbers	Piping Size "G" Thd.	Dimensions mm											Socket Head Cap Screw (4 Places)	O-Ring
		A	B	C	D	E	F	H	J	N	L	S		
HPV-F-0.75-U-T-10	3/4" BSP.F	72	53	47.6	22.2	20	28	11	17.5	11	18	35.5	3/8-16TPI UNC x 1-1/2	SO-NB-G30
HPV-F-0.75-M-T-10		M10 x 35Lg.												
HPV-F-1-U-T-10	1" BSP.F	73	50	52.4	26.2	21	30	11	15.5	11.5	16.5	43.5	3/8-16TPI UNC x 1-1/2	SO-NB-G35
HPV-F-1-M-T-10		M10 x 35Lg.												
HPV-F-1.25-U-T-10	1-1/4" BSP.F	85	56	58.7	30.2	24	38	13.5	20	13.5	20	53	7/16-14TPI UNC x 1-3/4	SO-NB-G40
HPV-F-1.25-M-T-10		M12 x 45Lg.												
HPV-F-1.5-U-T-10	1-1/2" BSP.F	96	72	69.9	35.8	24	30	13.5	21	14.5	19.5	59	1/2-13TPI UNC x 1-1/2	SO-NB-G50
HPV-F-1.5-M-T-10		M12 x 35Lg.												
HPV-F-2-U-T-10	2" BSP.F	105	77.5	77.8	42.9	24	32	13.5	21	13.5	19.5	73.5	1/2-13TPI UNC x 1-1/2	SO-NB-G65
HPV-F-2-M-T-10		M12 x 40Lg.												
HPV-F-2.5-U-T-10	2-1/2" BSP.F	118	102	88.9	50.8	31	46	13.5	21	13.5	18	86	1/2-13TPI UNC x 2	SO-NB-G75
HPV-F-2.5-M-T-10		M12 x 50Lg.												
HPV-F-3-U-T-10	3" BSP.F	138	138	106.4	62	30	41	17.5	26	17.5	26.5	100	5/8-11TPI UNC x 2	SO-NB-G90
HPV-F-3-M-T-10		M16 x 50Lg.												

### Welding Type

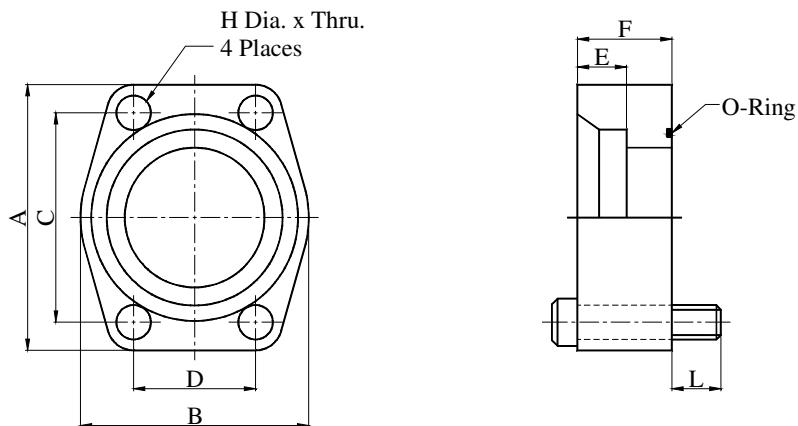

Kit Numbers	Piping Size "G" Thd.	Dimensions mm									Socket Head Cap Screw (4 Places)	O-Ring
		A	B	C	D	E	F	H	L			
HPV-F-0.75-U-W-10	3/4" BSP.F	65	48	47.6	22.2	12	30	11	15	3/8-16TPI UNC x 1-3/4	SO-NB-G30	
HPV-F-0.75-M-W-10		M10 x 45Lg.										
HPV-F-1-U-W-10	1" BSP.F	70	55	52.4	26.2	14	30	11	15	3/8-16TPI UNC x 1-3/4	SO-NB-G35	
HPV-F-1-M-W-10		M10 x 45Lg.										
HPV-F-1.25-U-W-10	1-1/4" BSP.F	80	64	58.7	30.2	16	38	13.5	22	7/16-14TPI UNC x 2-1/4	SO-NB-G40	
HPV-F-1.25-M-W-10		M12 x 60Lg.										
HPV-F-1.5-U-W-10	1-1/2" BSP.F	94	72	69.9	35.8	18	38	13.5	17	1/2-13TPI UNC x 2-1/4	SO-NB-G50	
HPV-F-1.5-M-W-10		M12 x 55Lg.										
HPV-F-2-U-W-10	2" BSP.F	102	85	77.8	42.9	20	38	13.5	22	1/2-13TPI UNC x 2-1/4	SO-NB-G65	
HPV-F-2-M-W-10		M12 x 60Lg.										
HPV-F-2.5-U-W-10	2-1/2" BSP.F	114	102	88.9	50.8	22	48	13.5	17	1/2-13TPI UNC x 2-3/4	SO-NB-G75	
HPV-F-2.5-M-W-10		M12 x 65Lg.										
HPV-F-3-U-W-10	3" BSP.F	135	116	106.4	62	25	48	17.5	27	5/8-11TPI UNC x 3	SO-NB-G90	
HPV-F-3-M-W-10		M16 x 75Lg.										

Typical Pump Characteristics Oil Viscosity 20 cSt [ISO VG 32, Temp 50°C]

• HPV22M-03

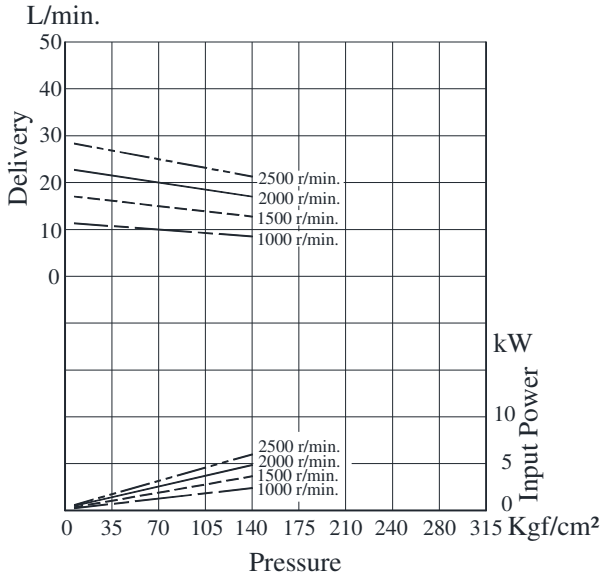

• HPV22M-05

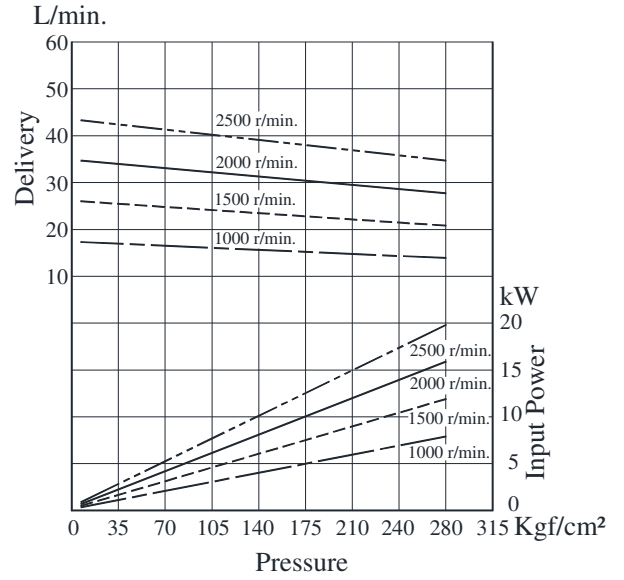

• HPV22M-06

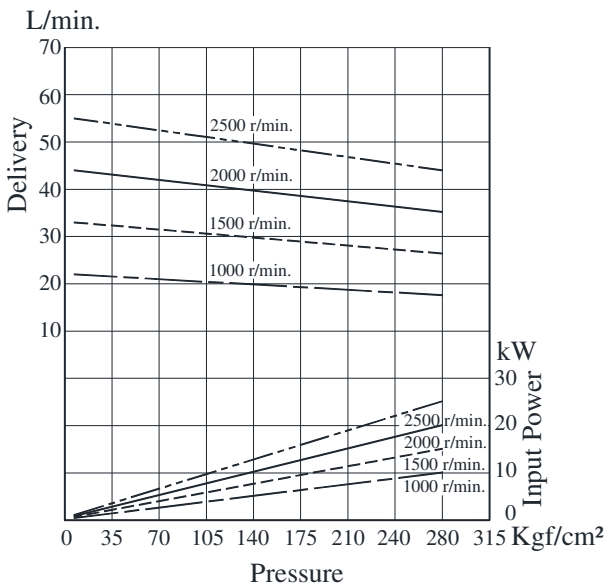

• HPV22M-08

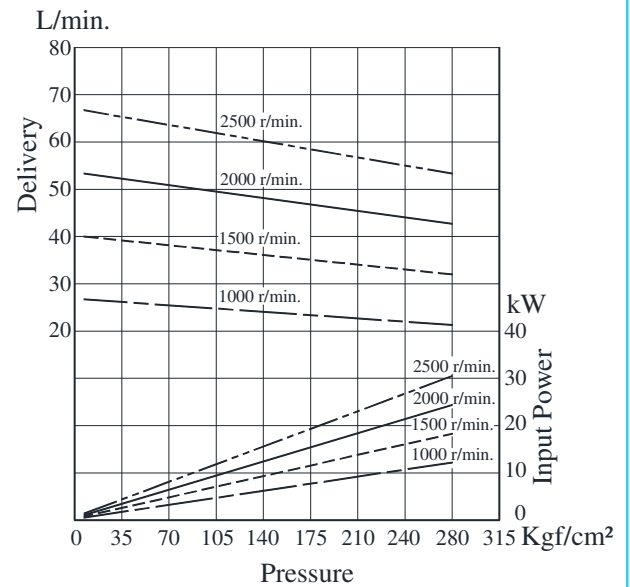

Typical Pump Characteristics Oil Viscosity 20 cSt [ISO VG 32, Temp 50°C]

● HPV22M-10

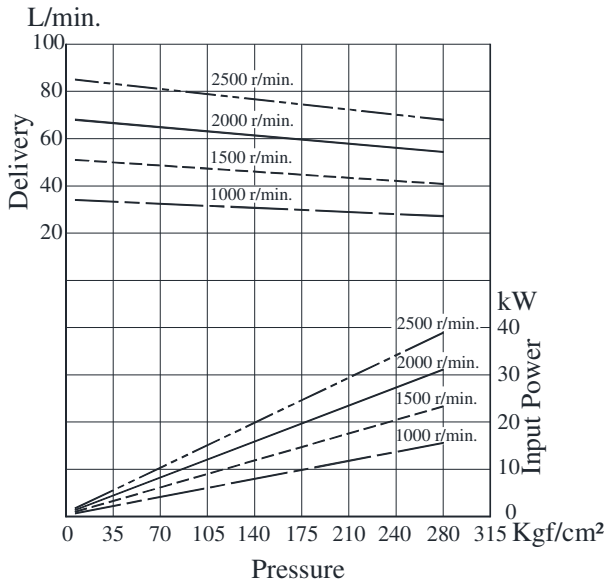

● HPV22M-12

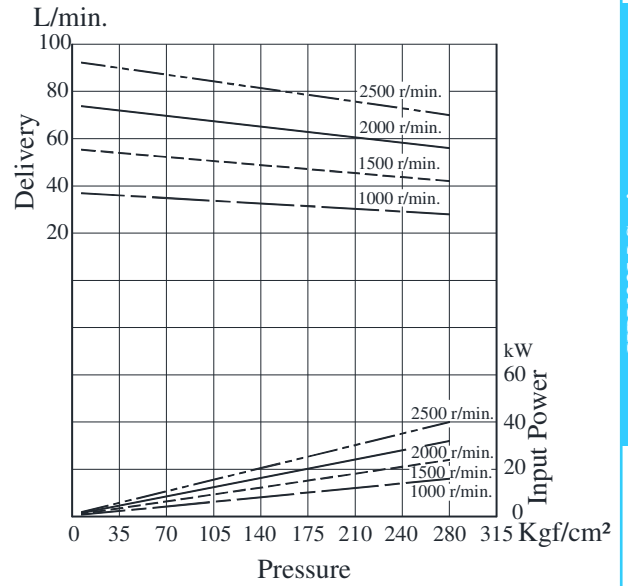

● HPV22M-14

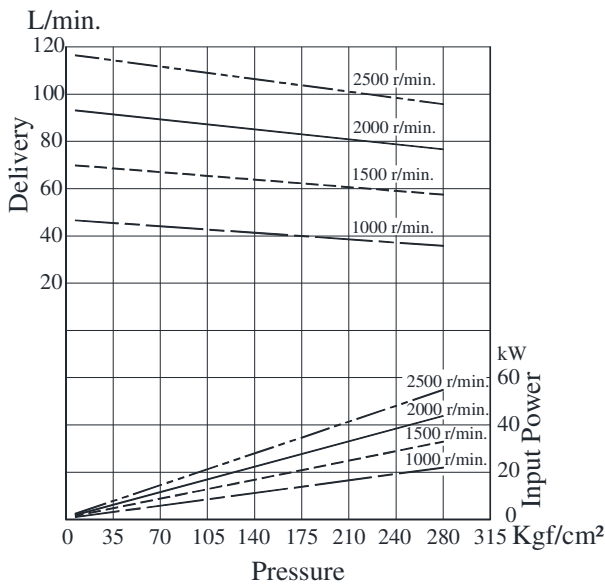

● HPV22M-15

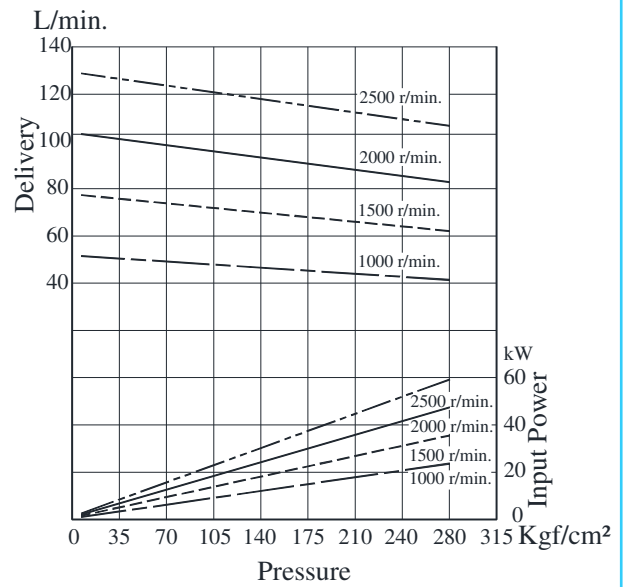

B  
HPV22M Series  
Double Vane Pumps

Typical Pump Characteristics Oil Viscosity 20 cSt [ISO VG 32, Temp 50<sup>0</sup>C]

• HPV22M-17

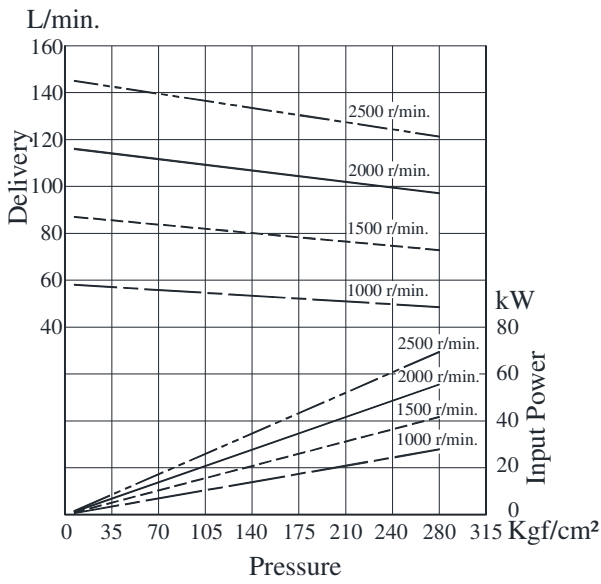

• HPV22M-20

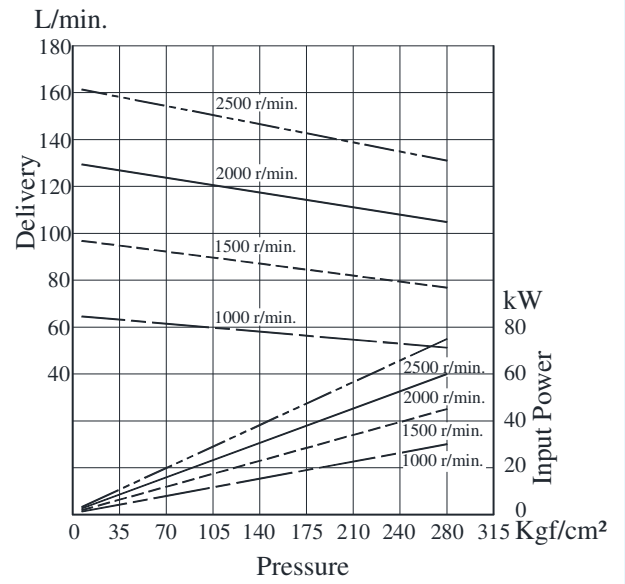

• HPV22M-22

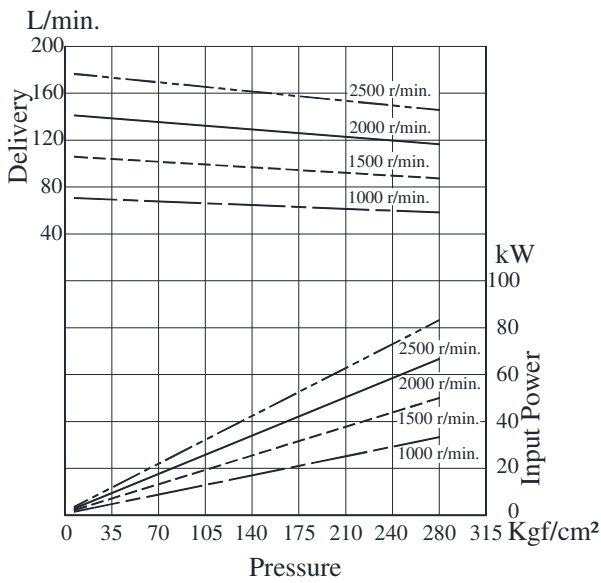

• HPV22M-25

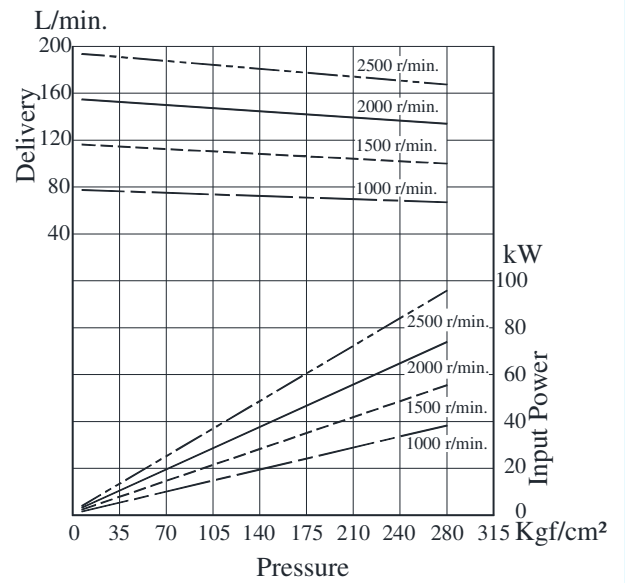



Typical Pump Characteristics Oil Viscosity 20 cSt [ISO VG 32, Temp 50°C]

● HPV22M-28

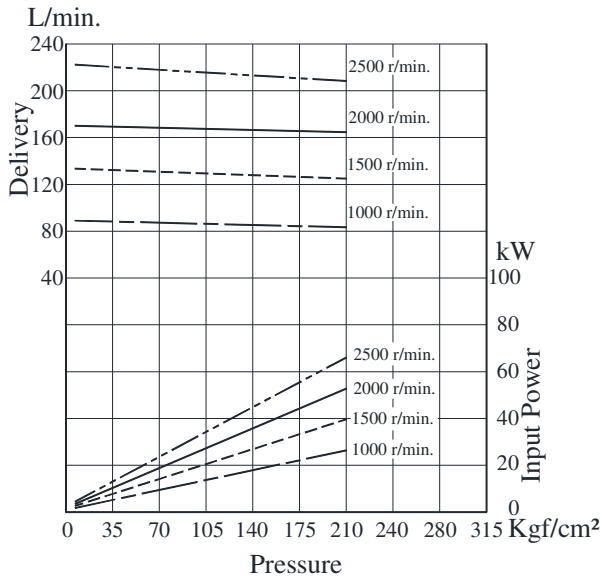

● HPV22M-31

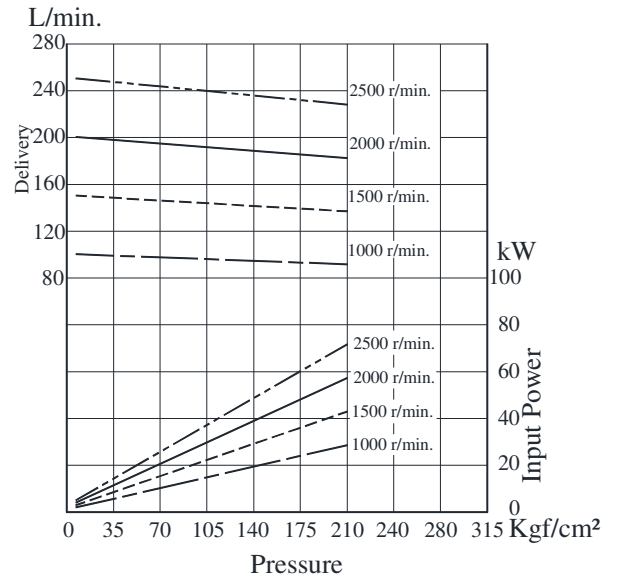

## HPV32M SERIES – HIGH PRESSURE HIGH SPEED DOUBLE PUMPS

These double pumps consist of one HPV3 and one HPV2 series single pump combined in tandem within a single housing and driven by a common shaft. Fluid delivered from the two-separate ports can be either supplied to separate or common circuits. These HPV pumps are designed for High-pressure function. Suitable for mobile applications like Drill rigs, Railways & Construction Equipments.



Graphic Symbol

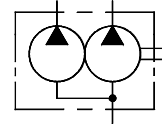

### Specifications

Model Number	Geometric Displacement $\text{cm}^3/\text{rev.}$				Max. Oper. Pressure $\text{Kgf/cm}^2$	Output Flow and Input Power	Shaft Speed Range r/min.		Mass (Approx.) Kg.	
	Series	1 <sup>st</sup> Section	Series	2 <sup>nd</sup> Section			Max.	Min.	Flange Mounting	Foot Mounting
HPV32M	14	47.6	03	10.8	275 <sup>*1</sup>	Ref. Page Nos. 220, 221, 222, 223, 228, 229 & 230	2500 <sup>*2</sup>	800	41.1	51.1
			05	17.2						
	17	58.2	06	21.3						
	20	66.0	08	26.4						
	24	79.5	10	34.1						
	28	89.7	12	37.1						
	31	98.3	14	46.0						
	35	110.0	15	50.5						
	38	120.3	17	58.3						
	42	136.0	20	63.8						
	45	145.7	22	70.3						
	50	158.0	25	79.3						
28			88.8							
61	190.5	31	100.0							

\*1 Different max. operating pressure for Small and Large Volume Pumps  
As follows

- Small Volume Pumps Series 28, 31 is 210  $\text{Kgf/cm}^2$ .
- Large Volume Pumps Series 50 is 210  $\text{Kgf/cm}^2$ .
- Large Volume Pumps Series 61 is 120  $\text{Kgf/cm}^2$  max. intermittent, 80  $\text{Kgf/cm}^2$  continuous.
- All other Larger Volume Pumps are limited to max. pressure of 240  $\text{Kgf/cm}^2$ .

\*2 Tandem pumps with Large Volume Pumps of series 42, 45, 50, 61 is 2200 r/min. max.

## Model Number Designation

HPV32M	-38	-17	-F	-R	A	A	A	-U0	-K1	-10
Model Number	Large Volume Pump Nominal Displacement	Small Volume Pump Nominal Displacement	Type of Mounting	Direction of Rotation	Large Volume Pump Discharge Port Position	Small Volume Pump Discharge Port Position	Suction Port Position	Mtg. W/ Conn. Variables	Type of Shaft	Design Number
					As Viewed From Shaft End					
HPV32M	14	03	<b>F:</b> Flange Mtg.  <b>L:</b> Foot Mtg.	<b>R:</b> Clockwise (Normal)  <b>L:</b> Anti-Clockwise				<b>U0, U1-</b> UNC port conn. (Refer table below)  <b>M0, M1-</b> Metric port conn. (Refer table below)	<b>K1-</b> Keyed (SAE-C)  <b>K2-</b> Keyed (No SAE)  <b>S1-</b> Splined (SAE-C)  <b>S2-</b> Splined (No SAE)	10

\* Design numbers subject to change from 10 to 19, but installation dimensions remain as shown.

\* For instructions regarding changing the port positions, consult YUKEN INDIA LTD.

### Mounting W / connection variables

Model Number	Mounting Type	1 <sup>st</sup> Discharge Port connection (D1)	2 <sup>nd</sup> Discharge Port connection (D2)	Suction Port connection (S)
HPV32M	U0	1"	1"	3"
	U1	1"	3/4"	3"
	M0	1"	1"	3"
	M1	1"	3/4"	3"

## Flanges

Note: Please refer page no. 219 for flange details.

## Cartridge Kit Model Number

### 1<sup>st</sup> Section Large Volume Discharge Port

CHPV32M	-38	-D1	-R	-10
Pump Series	Large Volume Nominal Displacement	Discharge Port	Shaft Rotation	Design Number
CHPV32M	14	<b>D1:</b> 1 <sup>st</sup> Section Discharge Port (Big)	<b>R:</b> Clockwise (Normal)  <b>L:</b> Anti-Clockwise	10

### 2<sup>nd</sup> Section Small Volume Discharge Port

CHPV32M	-17	-D2	-R	-10
Pump Series	Small Volume Nominal Displacement	Discharge Port	Shaft Rotation	Design Number
CHPV32M	03	<b>D2:</b> 2 <sup>nd</sup> Section Discharge Port	<b>R:</b> Clockwise (Normal)  <b>L:</b> Anti-Clockwise	10

\* For instructions regarding replacing cartridge kit, consult YUKEN INDIA LTD.

## Hydraulic Fluids

- Suction Pressure**  
 Suction line pressure limit  $-0.20\text{Kgf/cm}^2$  to  $+0.30\text{Kgf/cm}^2$
- Cleanliness**  
 Contamination level should be within NAS class 9. Use of  $100\mu\text{m}$ (150 mesh) tank filter on suction side, 50mm above the tank bottom surface.
- Alignment of Shaft**  
 Employ a flexible coupling whenever possible & avoid stress from bending or thrust. Maximum permissible misalignment is less than  $0.1\text{mm}$ (0.004Inches) TIR & maximum permissible misangular is less than  $0.2^\circ$ .

## Instructions

- Precautions at starting**  
 At an initial operation or at an operation after a long rest, the pump may have difficulty in sucking up fluids. In such cases, an air bleed valve should be installed before hand in the discharge side (Model No.ST1001-※-10※), or discharge air by slightly slackening the connection on the discharge side. At starting, operate the pump intermittently as far as possible with no load.
- Other Precautions**  
 If a pump is used at speed below 1200 r/min, install the pump with the suction port upside so that the pump can suck up fluid easily at starting.

## Spare Parts List

### List of Seals

Sl. No.	Name of Part	Part Number	Qty.
1	O-Ring	PKH4-0205	1
2	O-Ring	PKH4-0206	1
3	O-Ring	PKH4-0208	1
4	O-Ring	PKH4-0209	1
5	O-Ring	PKH4-0210	1
6	O-Ring	PKH4-0211	1
7	Backup-Ring	PKH4-0184	1
8	Backup-Ring	PKH4-0185	1
9	Oil Seal (NOK)	34.9x57.15x8.3	1

Note : When ordering the seals, please specify the seal kit number KS-HPV32-10.

## Foot Mounting Parts

Sl. No.	Name of Part	Part Number	Qty.
1	Mounting Bracket	PK2-10182-3	1
2	Socket Head Cap Screw	M16 x 45 Lg.	2
3	Spring Washer	WS-A-16	2

Note : When ordering the Foot Mounting Parts, please specify the Kit number HPV32-L-10.

HPV32M-\*\*-\*\*-\*\*-\*\*-\*\*-\*\*-\*\*-\*\*-10

● Flange Mounting

DIMENSIONS IN MILLIMETRES

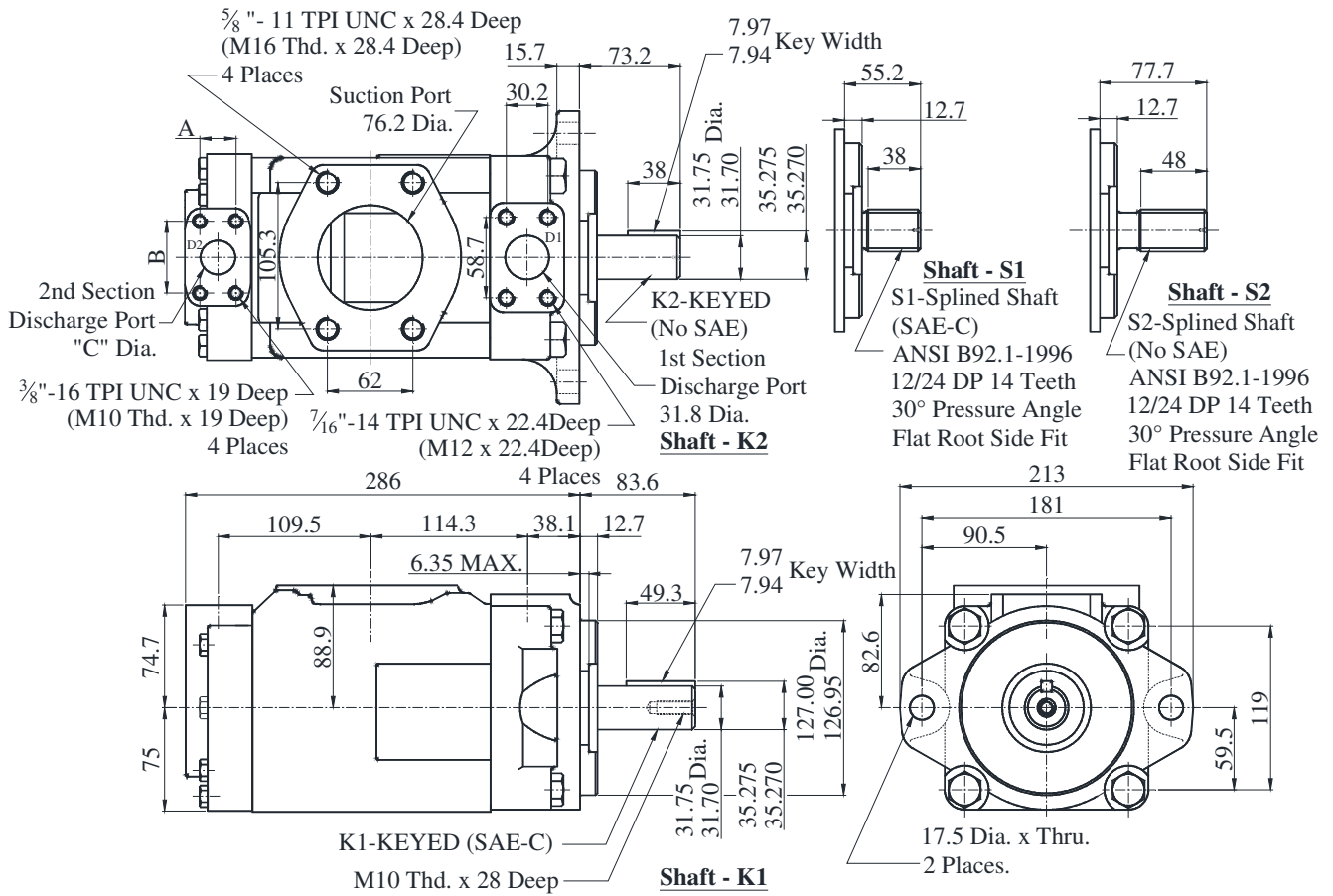

Alternate Connect. Variables

	U0 & M0	U1 & M1
A	26.2	22.2
B	52.4	47.6
C	25.4	19.05

● Foot Mounting

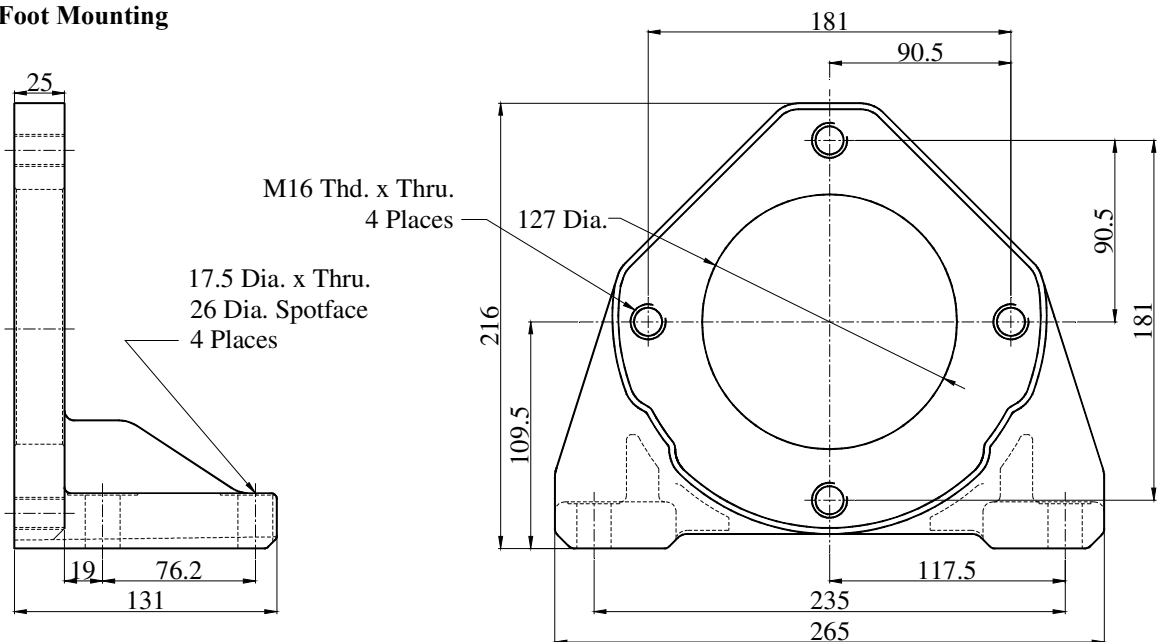

Note : For flanges and flange kit details refer page no. 5.

Typical Pump Characteristics Oil Viscosity 20 cSt [ISO VG 32, Temp 50<sup>0</sup>C]

● HPV32M-14

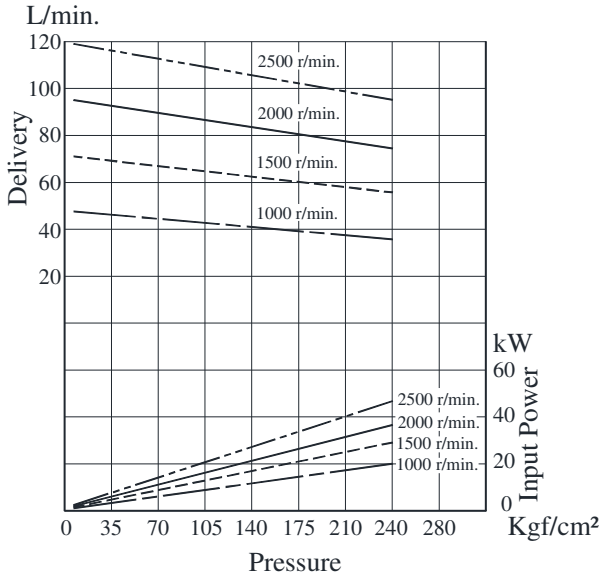

● HPV32M-17

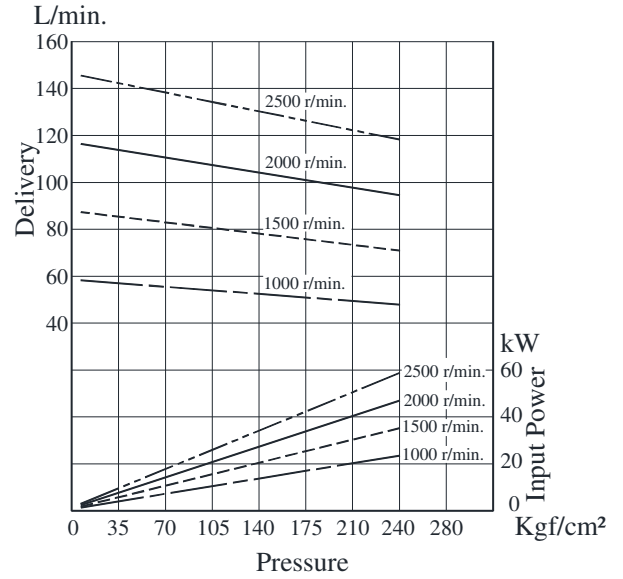

● HPV32M-20

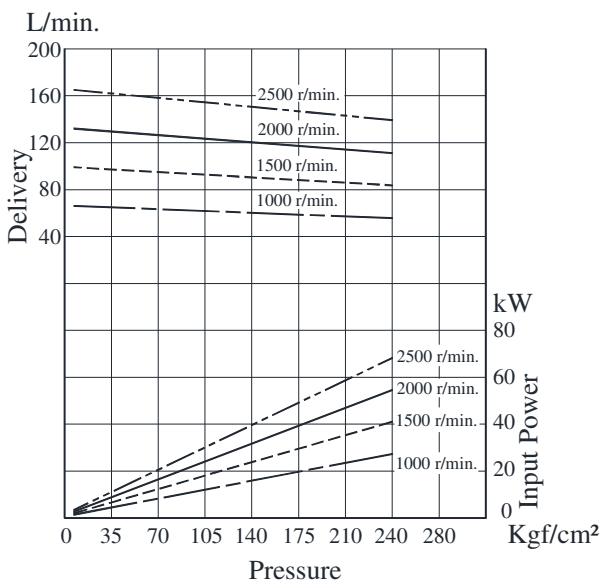

● HPV32M-24

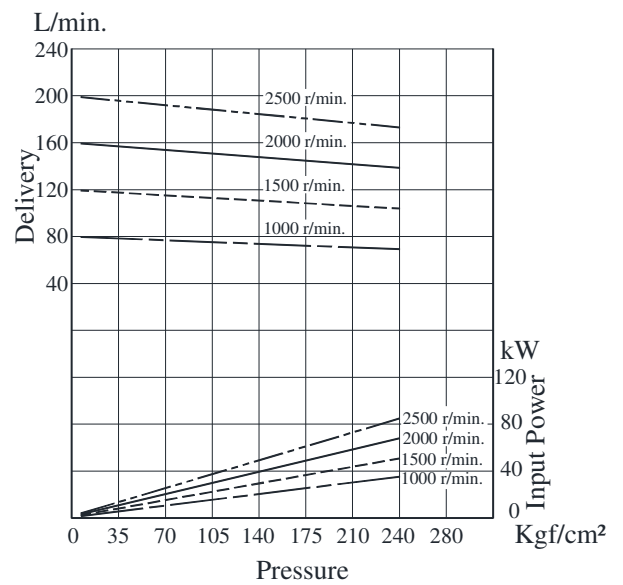

Typical Pump Characteristics Oil Viscosity 20 cSt [VG 32, Temp 50°C]

• HPV32M-28

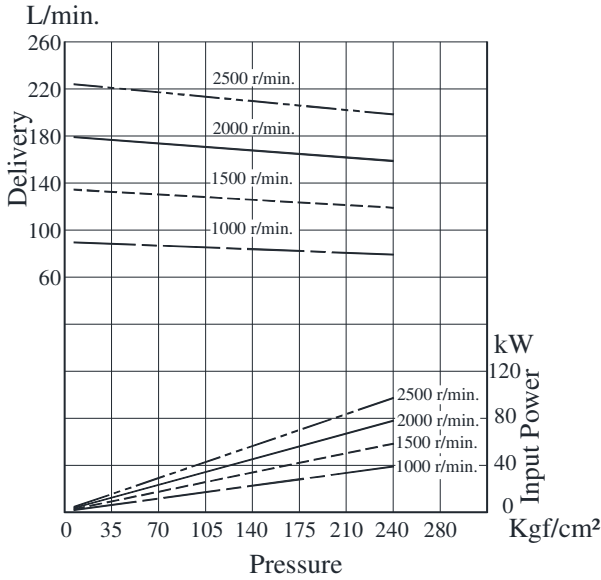

• HPV32M-31

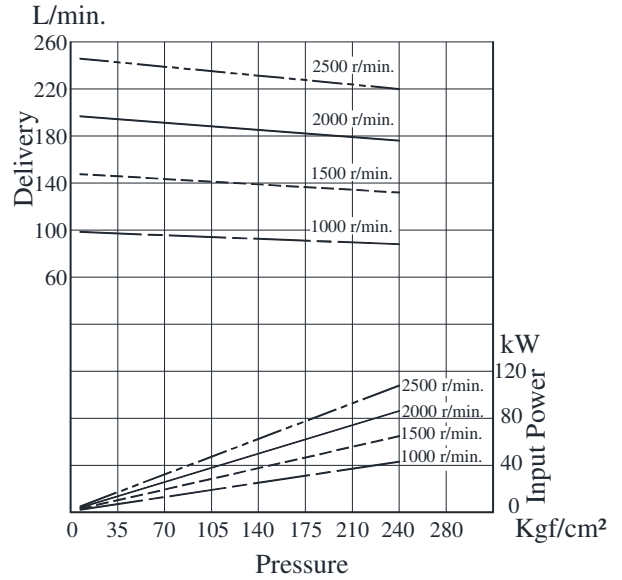

• HPV32M-35

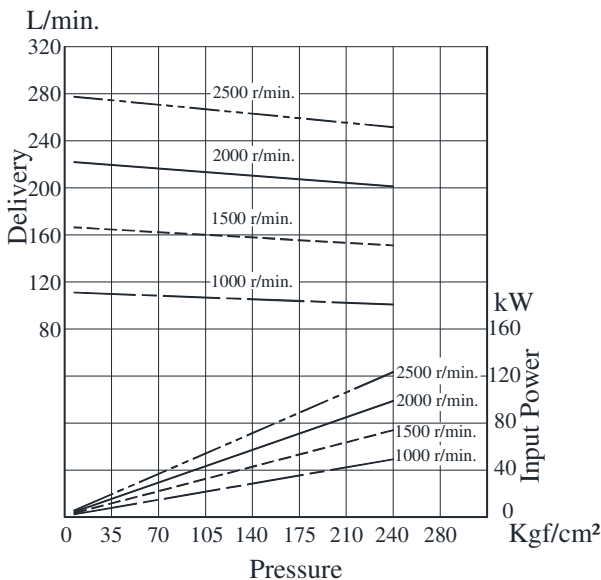

• HPV32M-38

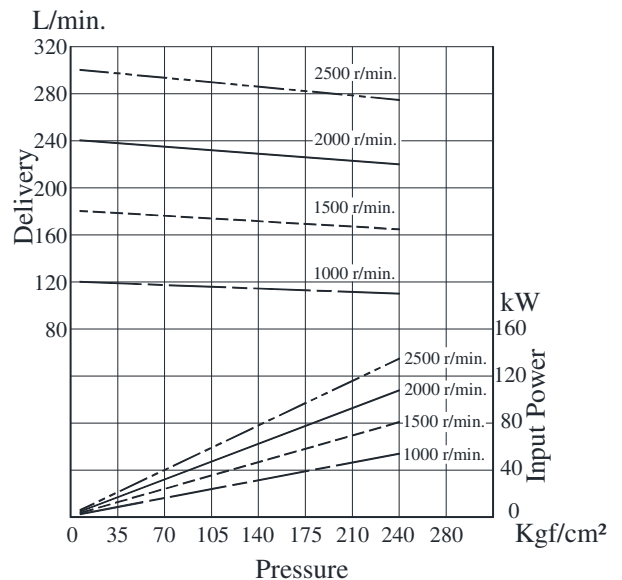

B  
HPV32M Series  
Double Vane Pumps

Typical Pump Characteristics Oil Viscosity 20 cSt [VG 32, Temp 50<sup>0</sup>C]

● HPV32M-42

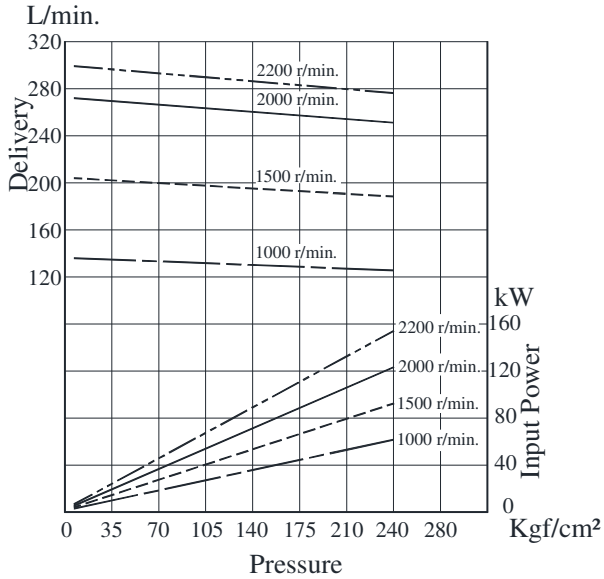

● HPV32M-45

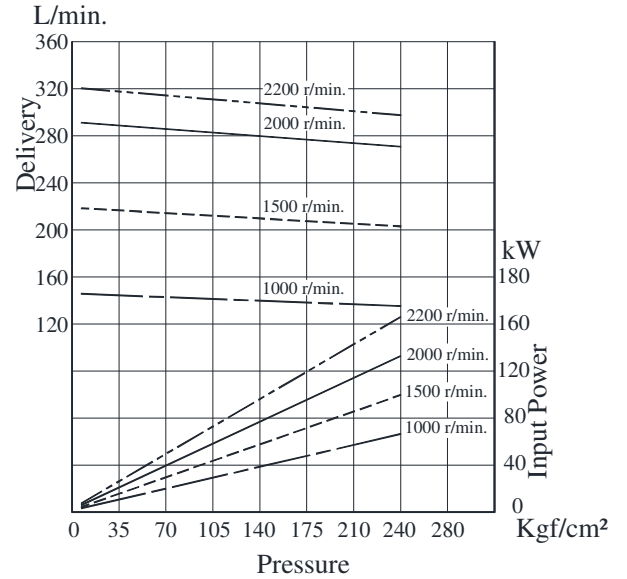

● HPV32M-50

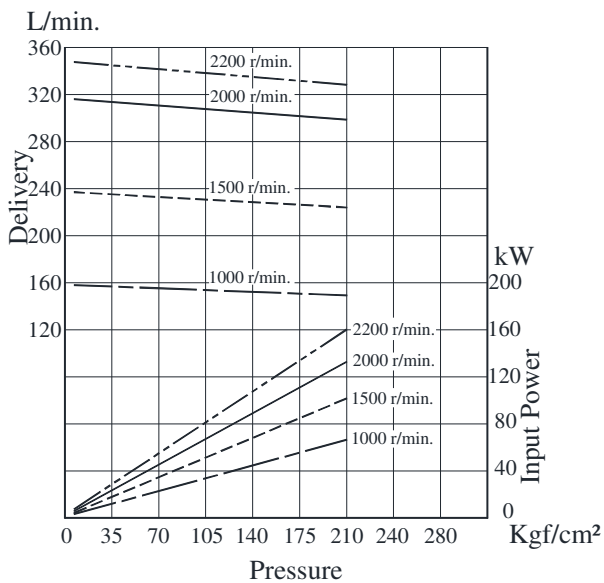

● HPV32M-61

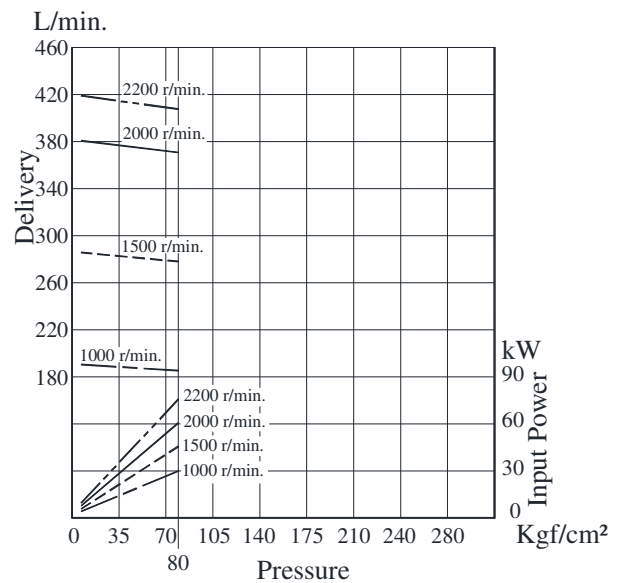

Note : For Typical Pump Characteristics of HPV2M, Refer Page no. 220, 221, 222 & 223.



**Cartridge Kit Model Number**

Pump Model Numbers	Cartridge Kit Number #	
	Small Volume Pump	Large Volume Pump
HPV22M- <sup>*</sup> -06- <del>※</del> -RAAA- <del>※</del> - <del>※</del> -10	CHPV22M-06-D2-L-10	CHPV22M- <sup>*</sup> -D1-R-10
HPV22M- <sup>*</sup> -10- <del>※</del> -RAAA- <del>※</del> - <del>※</del> -10	CHPV22M-10-D2-L-10	
HPV22M- <sup>*</sup> -14- <del>※</del> -RAAA- <del>※</del> - <del>※</del> -10	CHPV22M-14-D2-L-10	
HPV22M- <sup>*</sup> -17- <del>※</del> -RAAA- <del>※</del> - <del>※</del> -10	CHPV22M-17-D2-L-10	
HPV22M- <sup>*</sup> -22- <del>※</del> -RAAA- <del>※</del> - <del>※</del> -10	CHPV22M-22-D2-L-10	
HPV22M- <sup>*</sup> -28- <del>※</del> -RAAA- <del>※</del> - <del>※</del> -10	CHPV22M-28-D2-L-10	
HPV22M- <sup>*</sup> -31- <del>※</del> -RAAA- <del>※</del> - <del>※</del> -10	CHPV22M-31-D2-L-10	
HPV32M- <sup>*</sup> -05- <del>※</del> -RAAA- <del>※</del> - <del>※</del> -10	CHPV32M-05-D2-L-10	CHPV32M- <sup>*</sup> -D1-R-10
HPV32M- <sup>*</sup> -08- <del>※</del> -RAAA- <del>※</del> - <del>※</del> -10	CHPV32M-08-D2-L-10	
HPV32M- <sup>*</sup> -12- <del>※</del> -RAAA- <del>※</del> - <del>※</del> -10	CHPV32M-12-D2-L-10	
HPV32M- <sup>*</sup> -15- <del>※</del> -RAAA- <del>※</del> - <del>※</del> -10	CHPV32M-15-D2-L-10	
HPV32M- <sup>*</sup> -20- <del>※</del> -RAAA- <del>※</del> - <del>※</del> -10	CHPV32M-20-D2-L-10	
HPV32M- <sup>*</sup> -25- <del>※</del> -RAAA- <del>※</del> - <del>※</del> -10	CHPV32M-25-D2-L-10	

\* For instructions regarding replacing cartridge kit, consult YUKEN INDIA LTD.

# The above table does not include all combinations of cartridges available.  
Only a few representative samples are shown.