



Series VT6CP - B22 - 2 R 00 - A 1 *

Cam ring

Volumetric displacement cm^3/rev (in^3/rev)

- * B14/R14 = 46.0 (2.81)
- B15/R15 = 50.5 (3.08)
- B17/R17 = 58.3 (3.56)
- B20/R20 = 63.8 (3.89)
- B22/R22 = 70.3 (4.29)
- B25/R25 = 79.3 (4.84)
- B28/R28 = 88.8 (5.42)
- B31/R31 = 100.0 (6.10)

* 'B' - for Mobile
'R' - for Mobile - spring assisted

Type of shaft

- 2 - keyed (no SAE)
- 3 - splined (SAE C)
- X - splined

Modifications

Seal class

- 1 - S1 (for mineral oil)
- 4 - S4 (for fire resistant fluids)
- 5 - S5 (for mineral oil and fire resistant fluids)

Design letter

Porting combination

00 - standard

00

01

02

03

S - Suction port **P** - Pressure port

Direction of rotation (view on shaft end)

- R - clockwise
- L - counter-clockwise

INTERNAL LEAKAGE (TYPICAL)

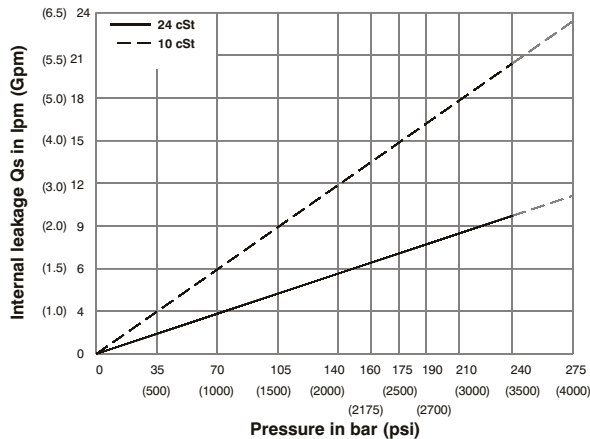

Do not operate pump more than 5 seconds at any speed or viscosity if internal leakage is more than 50% of theoretical flow.

NOISE LEVEL (TYPICAL)

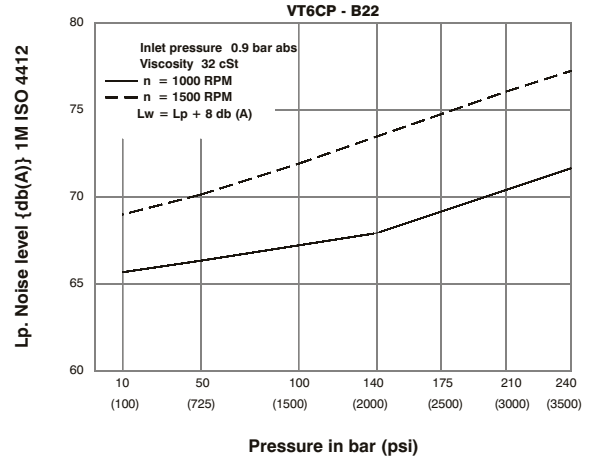

HYDROMECHANICAL POWER LOSS (TYPICAL)

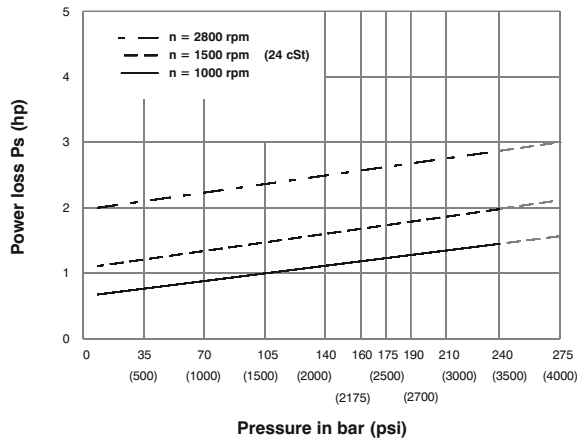

PERMISSIBLE RADIAL LOAD

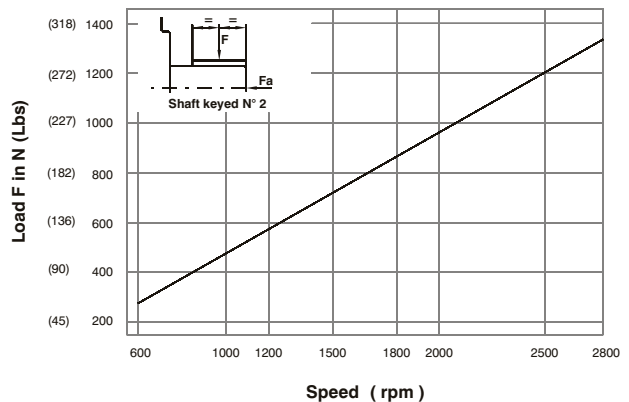

Maximum axial load permissible $F_a = 800 \text{ N}$ (180 Lbs)

SP

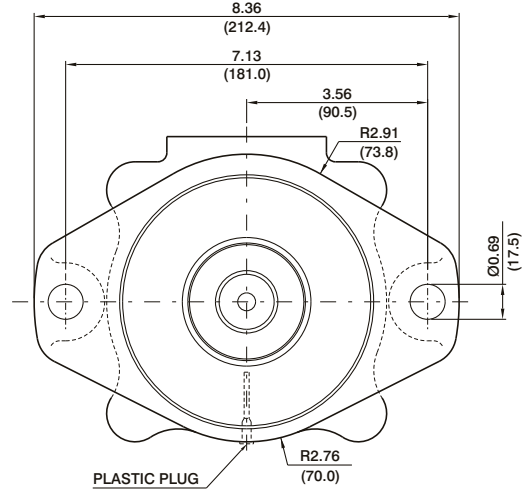
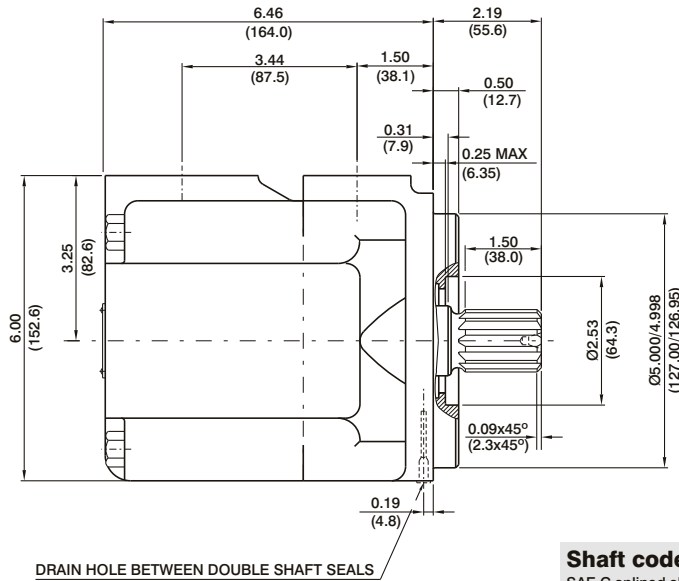
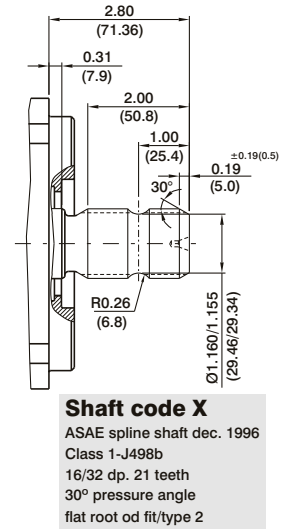
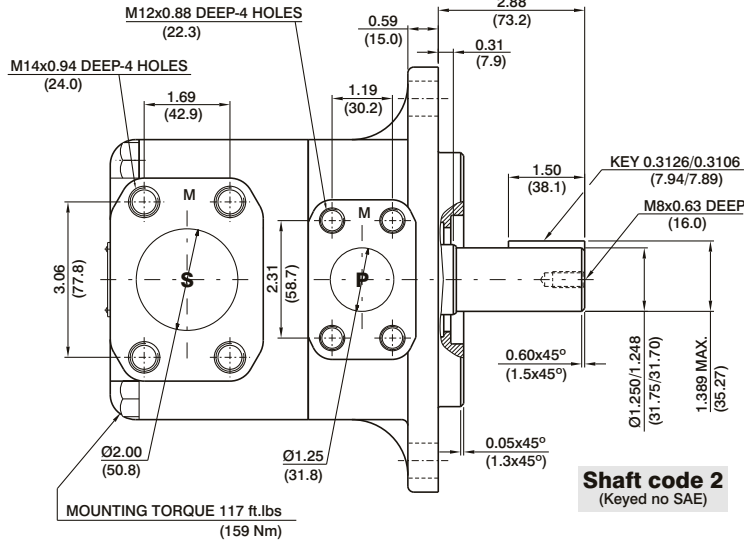

OPERATING CHARACTERISTICS - TYPICAL (24 cST)

Pressure port	Series	Volumetric Displacement V _p		Flow q & n = 1500 rpm						Input power p & n = 1500 rpm					
				p = 0 bar (0 psi)		p = 140 bar (2000 psi)		p = 240 bar (3500 psi)		p = 7 bar (100 psi)		p = 140 bar (2000 psi)		p = 240 bar (3500 psi)	
		in ³ /rev	cm ³ /rev	gpm	lpm	gpm	lpm	gpm	lpm	hp	kw	hp	kw	hp	kw
VT6CP	B14	2.81	46.0	18.25	69.0	16.79	63.5	15.60	59.0	2.55	1.9	23.60	17.6	39.56	29.5
	B15	3.08	50.5	20.00	75.6	18.62	70.4	17.46	66.0	2.68	2.0	25.61	19.1	42.91	32.0
	B17	3.56	58.3	23.12	87.4	21.69	82.0	20.50	77.5	2.82	2.1	29.37	21.9	49.48	36.9
	B20	3.89	63.8	25.32	95.7	23.86	90.2	22.67	85.7	2.95	2.2	31.92	23.8	53.91	40.2
	B22	4.29	70.3	27.88	105.4	26.45	100.0	25.26	95.5	3.08	2.3	35.00	26.1	59.14	44.1
	B25 ¹⁾	4.84	79.3	31.46	118.9	30.02	113.5	28.83	109.0	3.35	2.5	39.16	29.2	66.38	49.5
	B28 ^{1,2)}	5.42	88.8	35.24	133.2	33.78	127.7	32.93	124.5	3.75	2.8	43.85	32.7	73.04	54.5
	B31 ^{1,2)}	6.10	100.0	39.68	150.0	38.22	144.5	37.38	141.3	3.75	2.8	48.95	36.5	80.95	60.4

1) B25-B28-B31 = 2500 R.P.M. max.

2) B28-B31 = 210 bar (3000 psi) max. int.