



A Polyhydon Group Company

LEVER OPERATED DIRECTIONAL CONTROL VALVE DL10

ENGINEERING

1

Ref. No. D04909

Release 10/2013

Description

Completely encapsulated mechanism for protection against dirt. Five chamber design for better reduction in dynamic forces and longer valve life. Mounting styles -- Subplate body. Available as spring centred, spring off-set or detented model. Operating head can be rotated by 90° x 4 around spool axis for flexibility in mounting. Valve mounting interface conforms to International and National Standards. Port configuration conforms to Factory Standards.



Section

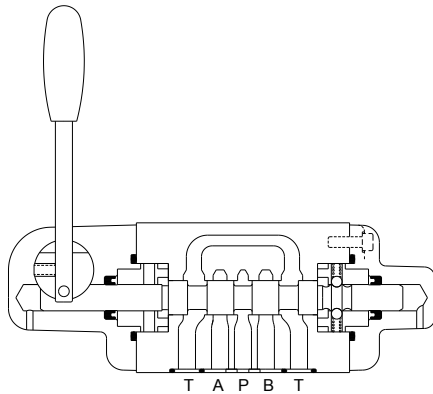

Hydraulic Symbol

2 position detented

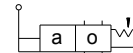

2 position spring offset

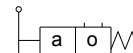

3 position detented

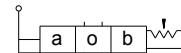

3 position spring centred

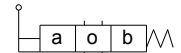

Unit dimension

Threaded mounting body :

Dimensions in mm.

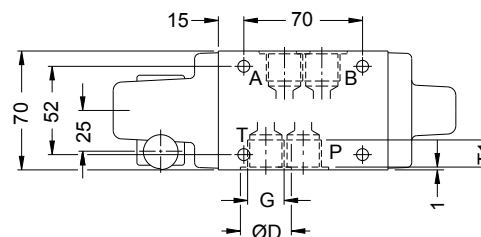
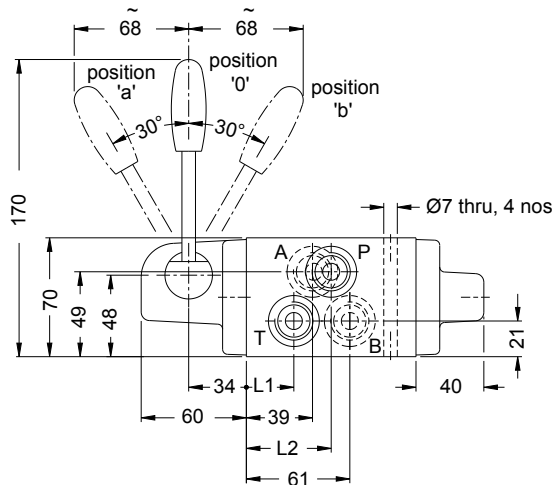

Size	G	ØD	T1	L1	L2
T02	G1/4	22	12	28	50
T03	G1/2	30	16	31	54

Polyhydon Pvt. Ltd.
78-80, Machhe Industrial Estate,
Machhe, Belgaum - 590 014. INDIA.

Phone : +91-(0)831-2411001
Fax : +91-(0)831-2411002
E-mail : polyhydon@gmail.com
Website : www.polyhydon.com

P04909



A Polyhydron Group Company

LEVER OPERATED DIRECTIONAL CONTROL VALVE DL10

ENGINEERING

2

Ref. No. D04909

Subplate mounting body :

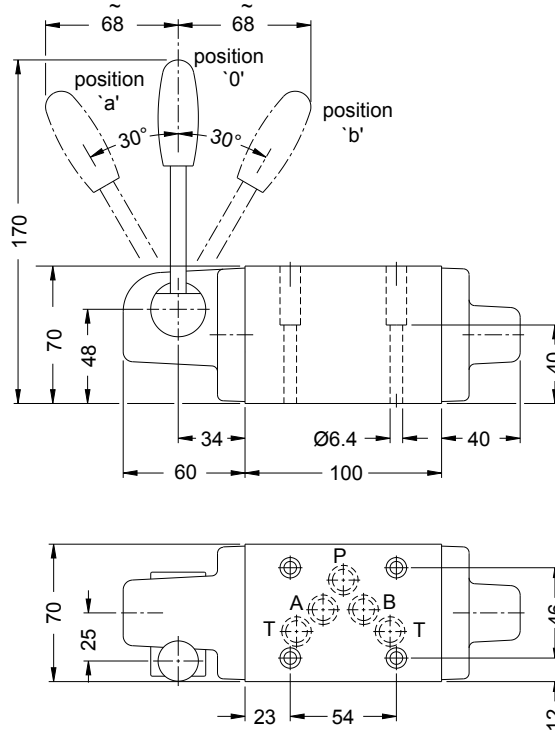

O'Ring size at port P, A, B & T : 12 i.d. x 2 c.s.d.

Subplate

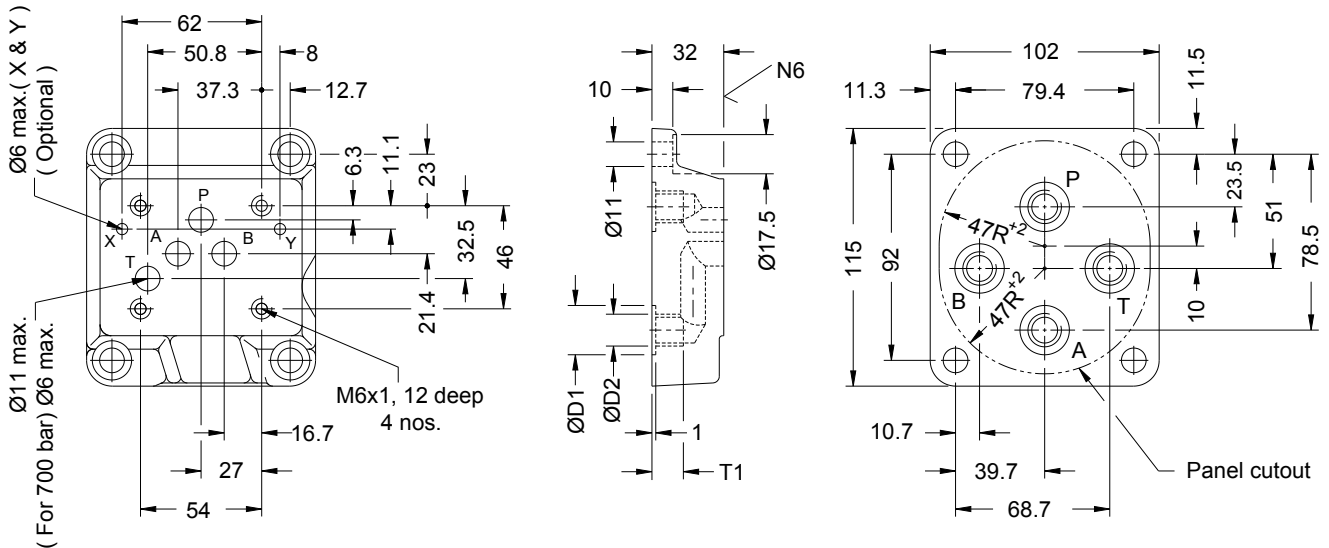

Subplate type	ØD1	ØD2	T1	Approx. mass	Valve fixing screws	Tightening torque
G101	22	G1/4	13	1.1 kg.	M6 x 50 L, 4 nos.	15 Nm
G102	25	G3/8	13			
G103	30	G1/2	15			

Note :

Surface roughness : Ra value is equal to or better than 0.8 µm
Surface flatness : 0.01 - 100 mm.



A Polyhydron Group Company

LEVER OPERATED DIRECTIONAL CONTROL VALVE DL10

ENGINEERING

3

Ref. No. D04909

Technical specification

Construction	Spool type.
Mounting	Subplate body. Interface as per ISO 4401-AC - 05 - 4 - A and IS 10187 - 10 mm. diameter nominal port.
Mounting position	Optional.
Flow direction	As per spool type.
Operating pressure	For port P, A and B 350 bar. (Standard valve) For port P, A and B 700 bar max. (High pressure valve) For port T 100 bar. (Both type)
Hydraulic medium	Mineral oil.
Viscosity range	10 cSt to 380 cSt.
Fluid temperature range	-20 °C to +70 °C.
Fluid cleanliness requirement	ISO 4406 20/18/15 or better.
Maximum flow handling capacity	Refer performance curves. (Standard valve) Multiply the curve values by 10 (High pressure valve)
Mass	5.6 kg. APPROX. (Subplate body)

Performance Curve

Oil used : ISO VG 68, Viscosity : 68 cSt @ 40 °C, Temp. @ test : 50 °C.

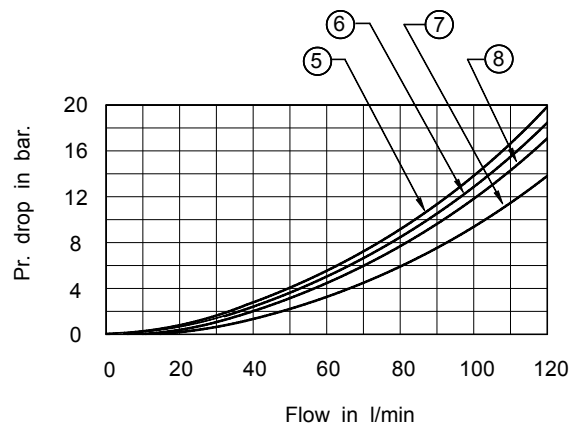
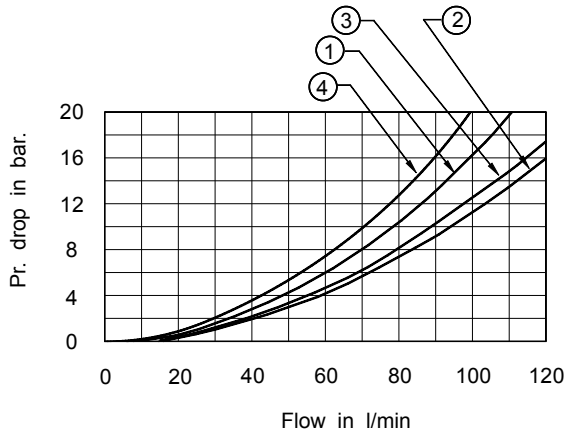

Table showing the relation between the spool type,
direction of flow & curve in the above graph to be referred to.

Spool type	Direction of flow / Curve no.				
	P to T	P to A	P to B	A to T	B to T
A	--	1	1	--	--
C	--	1	1	2	3
E	--	1	1	2	3
F	4	1	1	7	3
G	4	1	1	2	3
H	5	6	6	7	8
J	--	1	1	7	8
L	--	1	1	7	3
M	--	6	6	2	3
P	4	1	1	2	8
Q	--	1	1	2	3
W	--	1	1	2	3



A Polyhydron Group Company

LEVER OPERATED DIRECTIONAL CONTROL VALVE DL10

ENGINEERING

4

Ref. No. D04909

Ordering code

4 DL 10 S E D 700 V 10

3 Service port
4 Service port

Directional control valve
lever operated

Size 10

Subplate	S
Threaded	G1/4 T02 G1/2 T03

Spool type
Refer chart

Design code subject to
change. Installation
dimensions remain same.
for design code 10 thru 19.

V	Viton Seal
	Omit for Nitrile Seal

Omit	Standard valve
700	High pressure (700 bar max.)

D	Detension
S	Spring centred for 3 position valves
	Spring offset for 2 position valves

Spool chart.

Type	Symbol	Crossover	Type	Symbol	Crossover
A			Q		
C			U		
D			V		
E			W		
F			S1		
G			S2		
H			S3		
J			S4		
L			S5		
M			S6		
P					

Note : Subplate to be ordered separately.

All rights reserved.
Subject to revision.