

Yuken Logic Valves

Yuken's Logic Valves comprise cartridge type elements and covers with pilot passages. Various types may be combined for direction, flow rate and pressure control.

Yuken Logic Valves can be incorporated in manifold blocks to form optimum integrated hydraulic circuits and compact hydraulic power units. Being a poppet type, the elements permit high pressure, high flow rates, high speed and shock less shifting with low pressure drop.

Typical applications include steel mill machines, injection molding machines, machine tools and so on. In addition, Yuken Logic Valves cavity specifications confirm to ISO standards.

Features

- Multifunction performance in terms of direction, flow and pressure can be obtained by combining elements and covers.
- Poppet-type elements virtually eliminate internal leakage and Hydraulic locking. Because there are no overlaps, response time is very high, permitting high-speed shifting.
- For high pressure, large capacity systems, optimum performance is achieved with low pressure losses.
- Since the logic valves are directly incorporated in cavities provided in blocks, the system is free from problems related to piping such as oil leakage, vibration and noise, and higher reliability is achieved.
- Multifunction logic valves permit compact integrated hydraulic systems which reduce manifold dimensions, mass and achieve lower cost compared to conventional types.

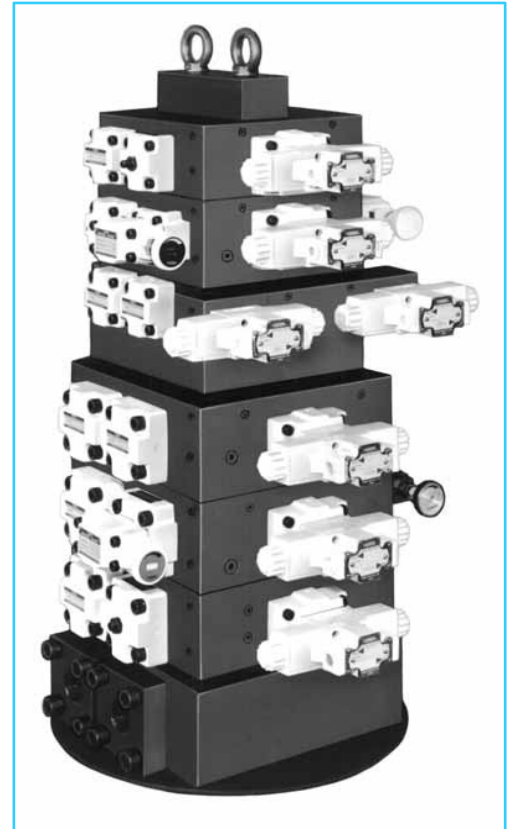

Logic Valves

Structure and functions

As shown below, a logic valve consist of a cover, a sleeve, a poppets and a spring incorporated in a block. Although it is a simple 2-port valve designed to open and close the poppets in accordance with the pressure signals from the pilot line, it serves as a multifunctional valve for controlling the direction, flow and pressure by controlling the pressure signals. Standard covers have several pressure signal ports (pilot ports) and control valves for control purpose are available. The covers are spigot mounted. There is no risk of oil leakage.

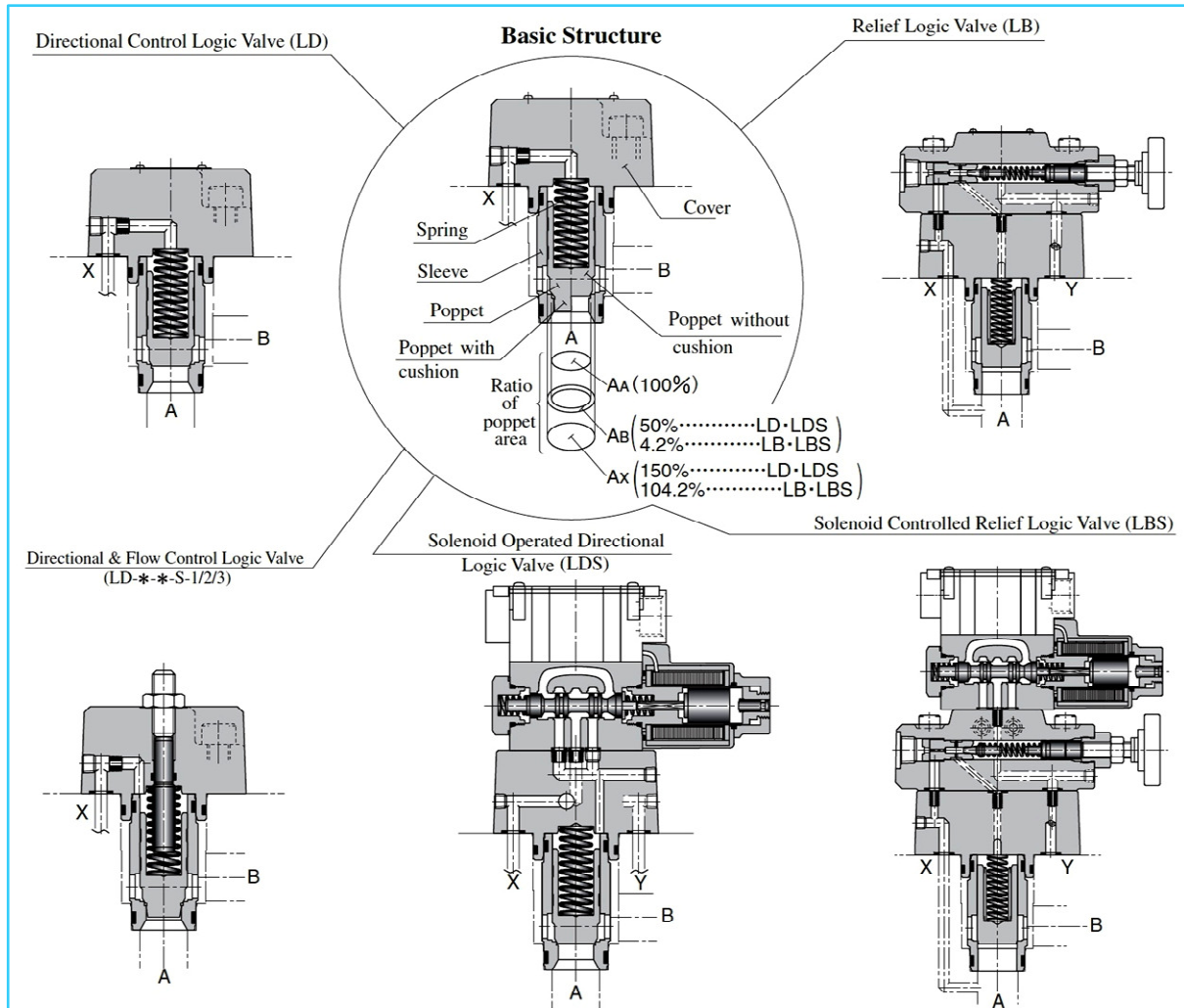

● **Functions, Working area ratios and features**

Functions	Graphic Symbols	Working area ratio (AA : AB)	Features
Direction		(2 : 1)	<ul style="list-style-type: none"> • Poppet shape • Without cushion (LD/LDS-**-*) : high speed shift/ • With cushion (LD/LDS-**-S) : Shockless shift • No leakage between port A and B • Flow A to B and B to A are possible • Response time and shock can be adjusted by orifice Selection.
Direction and Flow			<ul style="list-style-type: none"> • Poppet shape • With cushion (LD -**-S-1/2/3) : flow control • No leakage between port A and B • Flow A to B is possible • Response time and shock can be adjusted by orifice Selection.
Relief		(24 : 1)	<ul style="list-style-type: none"> • Remote and unloading control is possible with vent circuit (LB-**-*) . • Two or three pressure controls are possible in Combination of solenoid operated directional valve and Pilot relief valve (LBS-**-*) .

Operating Principles

The logic valve poppet is opened or closed by the pilot pressure balance between the pilot port “X” and the poppet force produced by the pressure at A and B ports.

If

A_x : area under pressure at port X

A_A : area under pressure at port A

A_B : area under pressure at port B

P_x : pressure at port X

P_A : pressure at port A

P_B : pressure at port B

F_s : spring force

F_x : pressing force at port X

F_w : push-up force at port A and B

Then

$$(A_x * P_x) + F_s = F_x$$

$$(A_A * P_A) + (A_B * P_B) = F_w$$

Closing Operation

If the solenoid operated directional valves (SOL) at pilot port X is “off” in the figure below, there is the following relation:

$$F_x > F_w$$

Here, the poppet is pushed on to the seat and the valve closes.

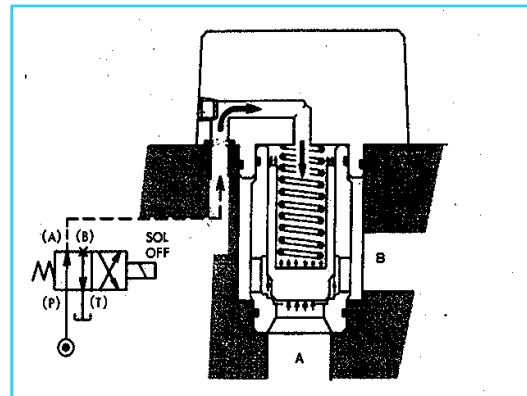
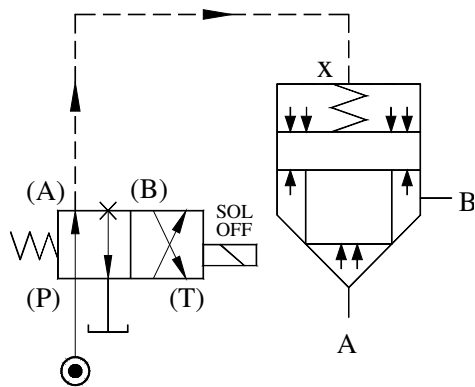

Opening Operation

If the solenoid operated directional valves (SOL) at pilot port X is “on” in the figure below, there is the following relation:

$$F_x < F_w$$

Here, the poppet is pushed up from the seat and the valve opens.

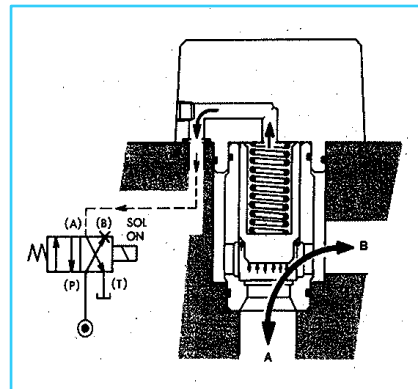
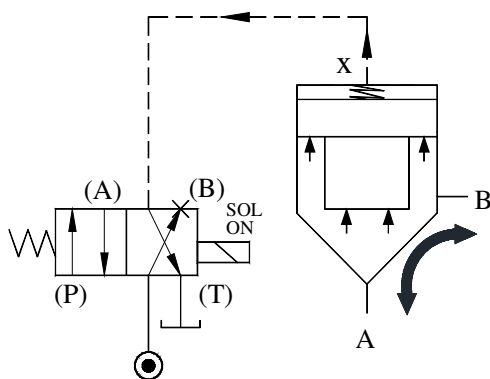

Directional Control Logic Valves
Directional and Flow Control Logic Valves

The valves mentioned above are 2-way directional valves designed to open and close the circuits in accordance with pressure signals from the pilot lines. They are used as multifunctional valves for controlling flow directions or flow directions and rates.

Standard covers provided with a choice of several control valves are available so that optimum valves can be selected for control purposes.



Specifications

Model No.	Rated Flow L/min.	Max. operating Pressure Kgf/cm ²	Cracking Pressure Kgf/cm ²	Ratio of Poppet area	Mass Kg
LD-16	130	315	None: No Spring 05: 0.5 (A→B) [1 (B→A)] 20: 2 (A→B) [4 (B→A)]	2:1 (Annular area 50%)	1.6
LD-25	350				3.0
LD-32	500				5.3
LD-40	850				9.1
LD-50	1400				14.8
LD-63	2100				29.8

Note: The rated flow is values with pressure drop of 3 Kgf/cm² [Fluid viscosity 35cSt]

Model Number Designation

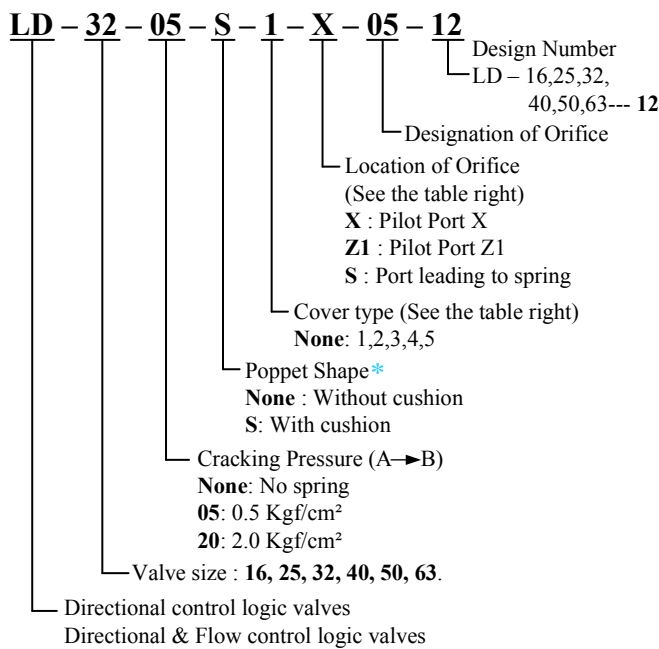

*** Poppet Shapes**

The type without a cushion and the type with a cushion are both suitable for high-speed shifting and shock less shifting respectively. For directional and flow control logic valves, be sure to specify “Poppets with cushions”.

List of Cover Types

Cover Type Designation	Graphic Symbols	Valve Size					
		16	25	32	40	50	63
Directional Control	Standard (None)	○	○	○	○	○	○
	With Check Valve (4)	○	○	○	○	○	○
	With Shuttle Valve (5)	○	○	○	○	○	○
Directional & Flow Control	With Stroke Adjuster (1)	○	○	○	○	○	○
	With Check Valve & Stroke Adjuster (2)	○	○	○	○	○	○
	With Shuttle Valve & Stroke Adjuster (3)	○	○	○	○	○	○

Solenoid Operated Directional Control Valves

The solenoid operated directional control logic valves are composed of directional control valves and solenoid operated directional valves combined together. The solenoid operated directional valves serve to switch pilot lines and the directional control valves are used to control the direction of the main circuits.

Covers provided with various control valves are available to provide optimum control.

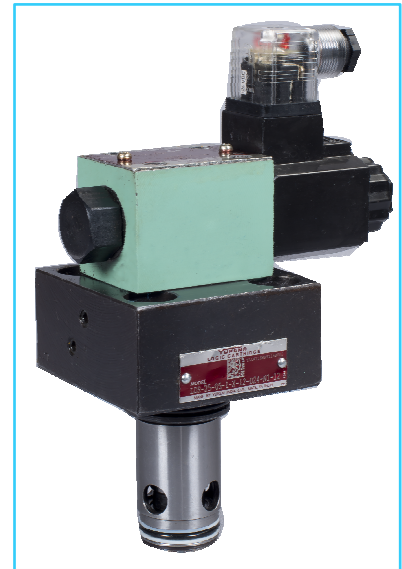

Specifications

Model No.	Rated Flow L/min	Max. operating Pressure Kgf/cm ²	Cracking Pressure Kgf/cm ²	Ratio of Poppet area	Mass Kg
LDS-16	130	315	None: No Spring 05: 0.5 (A→B) [1 (B→A)] 20: 2 (A→B) [4 (B→A)]	2:1 (Annular area 50%)	3.0
LDS-25	350				4.4
LDS-32	500				6.7
LDS-40	850				10.5
LDS-50	1400				18.6
LDS-63	2100				33.6

Note: The rated flow is values with pressure drop of 3 Kgf/cm² [Fluid viscosity 35cSt]

Model Number Designation

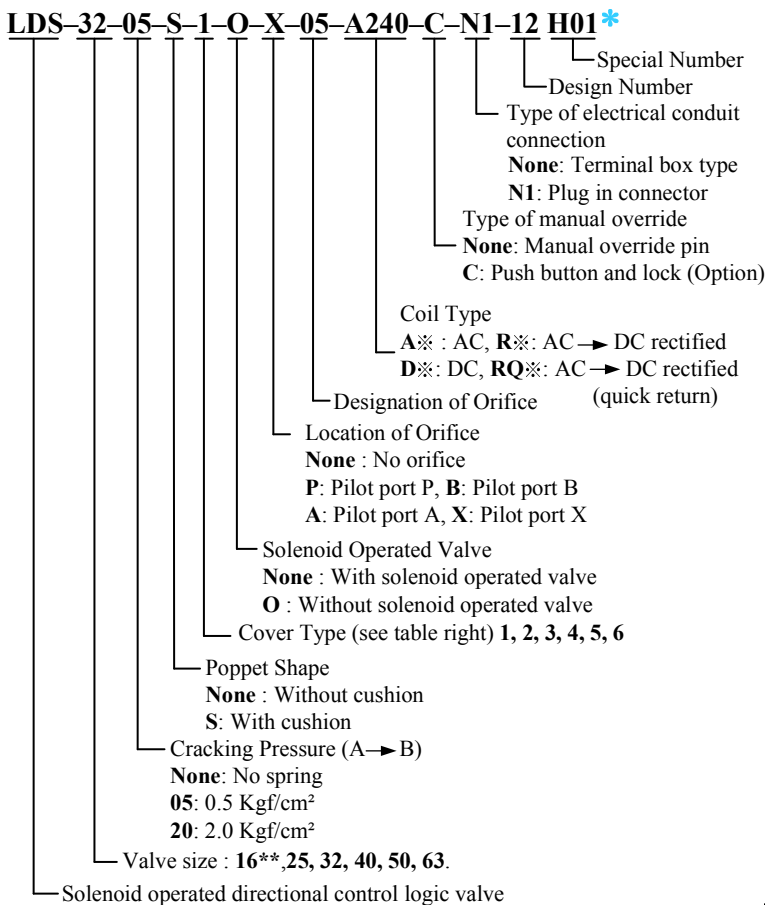

List of Cover Types

Cover Type Designation	Graphic Symbols	Valve Size				
		25	32	40	50	63
Normally Closed (1)		O	O	O	O	O
Normally Open (2)		O	O	O	O	O
Normally Closed with Shuttle Valve (3)		O	O	O	O	O
Normally Open with Shuttle Valve (4)		O	O	O	O	O
Normally Closed with Shuttle Valve (5)		O	O	O	O	O
Normally Open with Shuttle Valve (6)		O	O	O	O	O

Note: In case LDS-**-**-**-O (without solenoid operated valve), the graphic symbol for the solenoid operated valve is excluded.

* H01 → Only for LDS-16

** LDS-16 available only with cover type 1 & 2. Consult factory when cover type 3,4,5 & 6 is required.

Orifices

Valve response time and shock level can be adjusted by changing the orifice diameter on the pilot line. Favorable response and shock less effect can be obtained by selecting an optimum orifice diameter.

How to select orifices

An orifice diameter can be obtained by using Figs. 1 & 2 and only if a response time and a pressure differential at the orifice are determined.

Example:

Model No. : LD-40 (poppet without cushion)

Pressure differential at orifice : 5 Kgf/cm²

Necessary response time : 0.1 s.

Under these conditions, obtain the orifice diameter. Obtain the pilot flow rate by drawing lines in fig. 1 as shown by the dotted lines. In this example it is 14 L/min. Draw lines in Fig 2 as shown by the dotted lines to obtain the cross section. In this example, it is 2.0 mm.

Notes :

- 1) The response time refers to the times from when the solenoid of the solenoid operated directional valve is energized to when the main valve fully closes after full stroke.

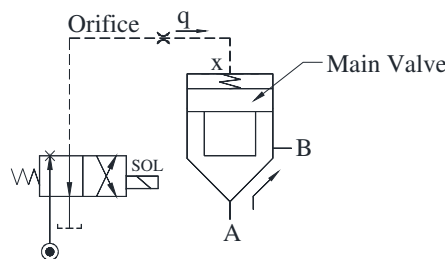

- 2) If logic valves are used at pressure above 200 Kgf/cm² maximum orifice diameters are limited.

Valve Size	16	25	32	40	50	63
Designation of Orifice	12	12	14	16	18	20
Orifice Dia. (ø)	1.2	1.2	1.4	1.6	1.8	2.0

Fig.1 Pilot Flow Rate Vs. Response Time Characteristics Valve size of Logic Valve

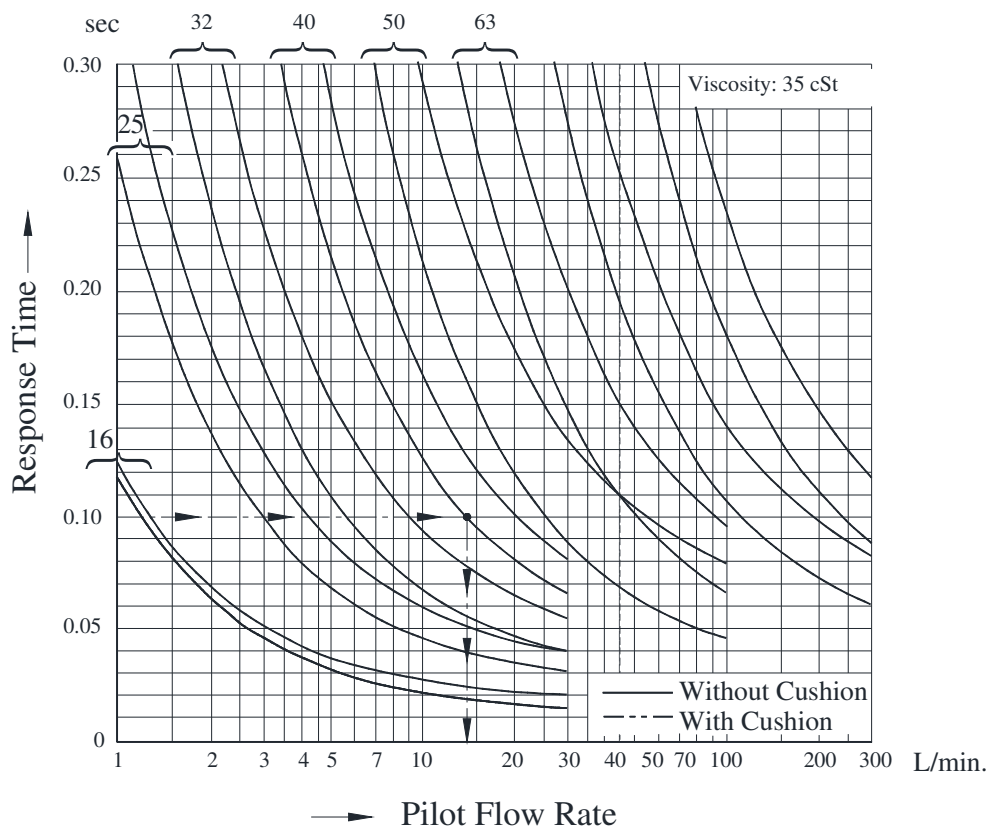

Solenoid Operated Directional Control Logic Valves

• **Orifice types and standard orifice diameters**

Standard orifice diameters for orifice types are shown below.

Standard Orifice		Orifice Type			
Designation Of Orifice	Orifice Dia. "d" mm	TP-OPM -4 x d	TP-OPT -1/16 x d	TP-OPT -1/8 x d	TP-OPT -3/8 x d
05	0.5	0	0	0	-
06	0.6	0	0	-	-
08	0.8	0	0	0	-
10	1.0	0	0	0	-
12	1.2	0	0	0	-
14	1.4	0	0	0	-
16	1.6	0	0	0	0
18	1.8	-	0	0	0
20	2.0	-	0	0	0
25	2.5	-	0	0	0
32	3.2	-	-	0	0
40	4.0	-	-	-	0
50	5.0	-	-	-	0
Recommended tightening torque Kgf-cm		17	55	105	500

Fig.2 Pilot Flow Rate Vs. Differential Pressure Characteristics

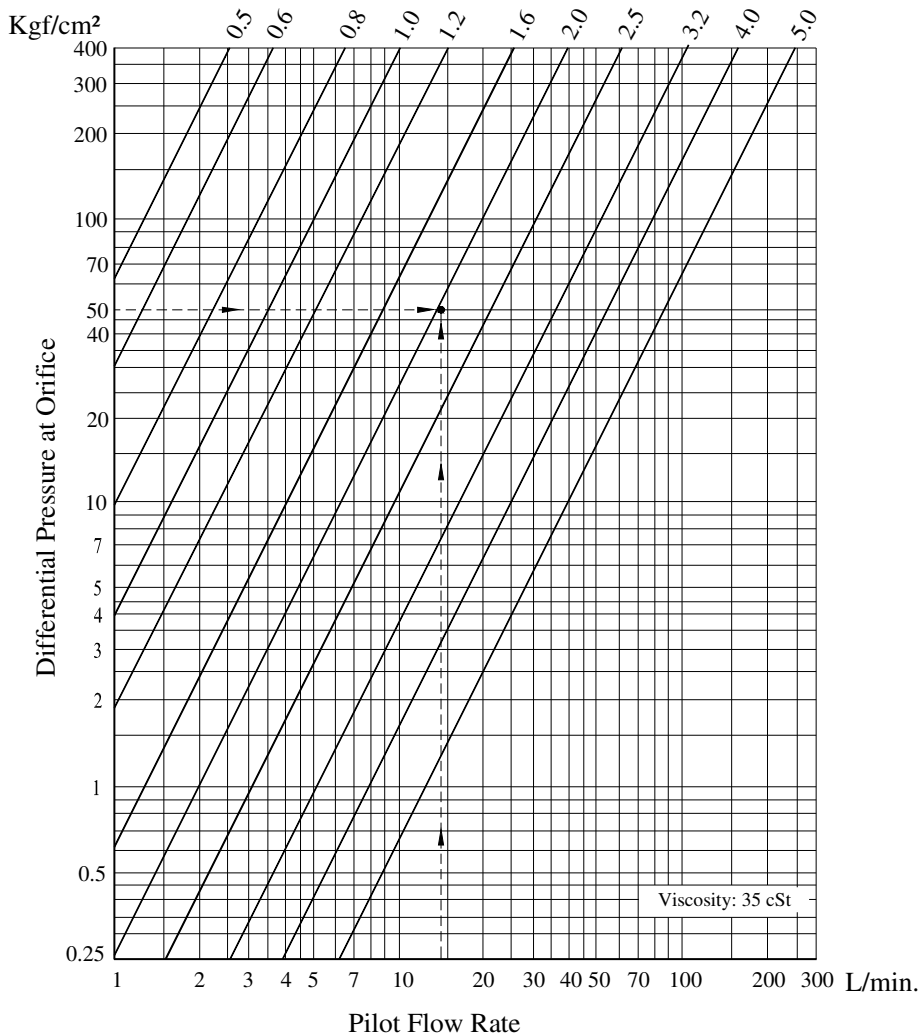

Typical Valve Characteristics Oil Viscosity 35 cSt [ISO VG 46, Temp 50⁰ C]

Flow rate Vs. Pressure

Ex: Cracking Pressure A→B 2Kgf/cm² is required

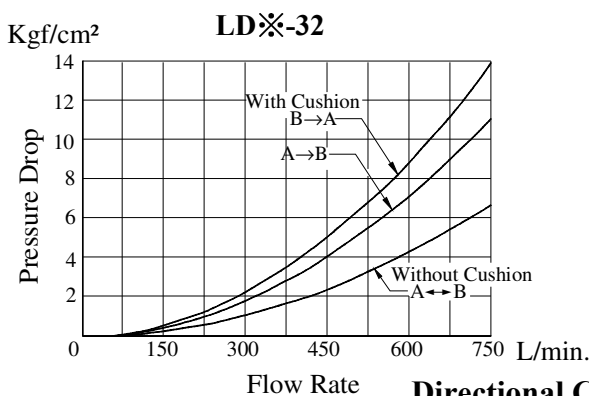
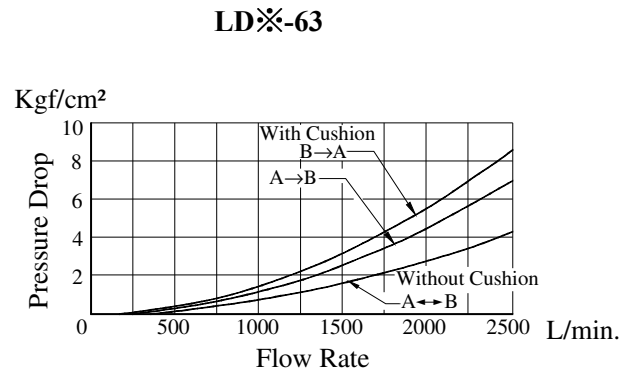
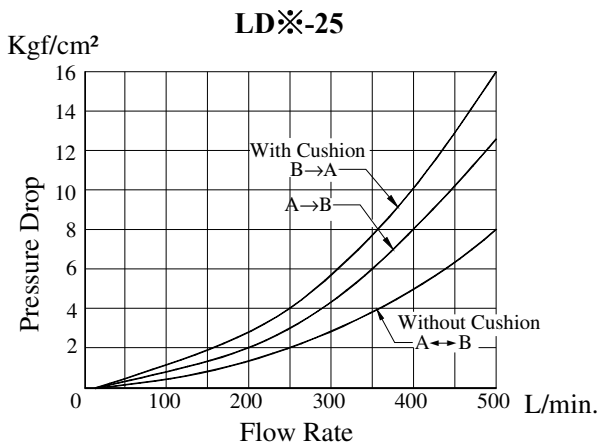
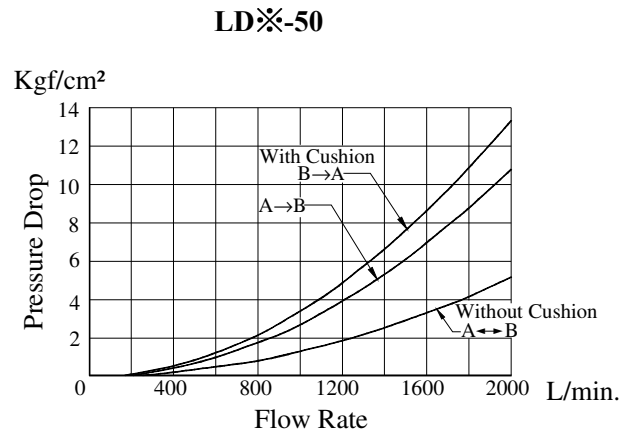
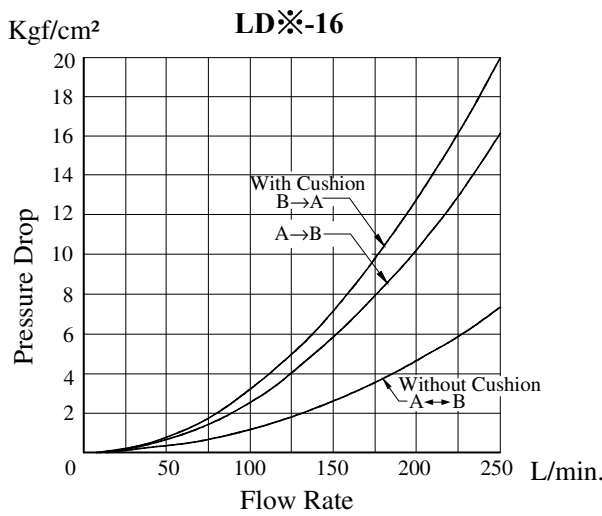
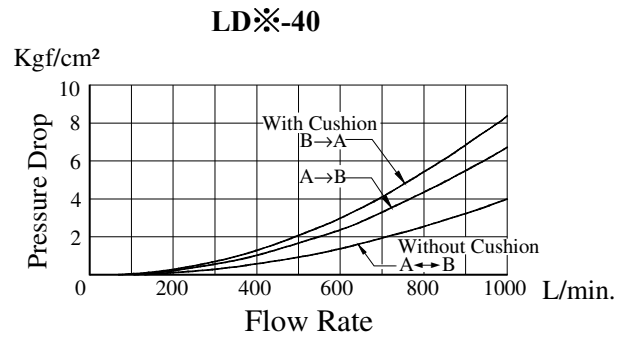
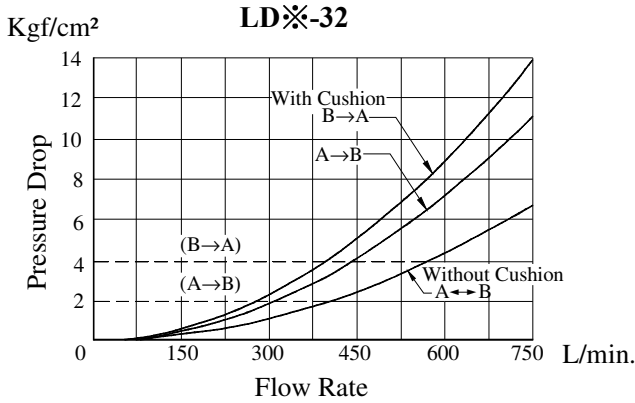

Directional Control Logic Valves

Solenoid Operated Directional Control Logic Valves

Typical Valve Characteristics Oil Viscosity 35 cSt [ISO VG 46, Temp 50⁰ C]

Adjustment Screw revolution Vs. Flow Rate

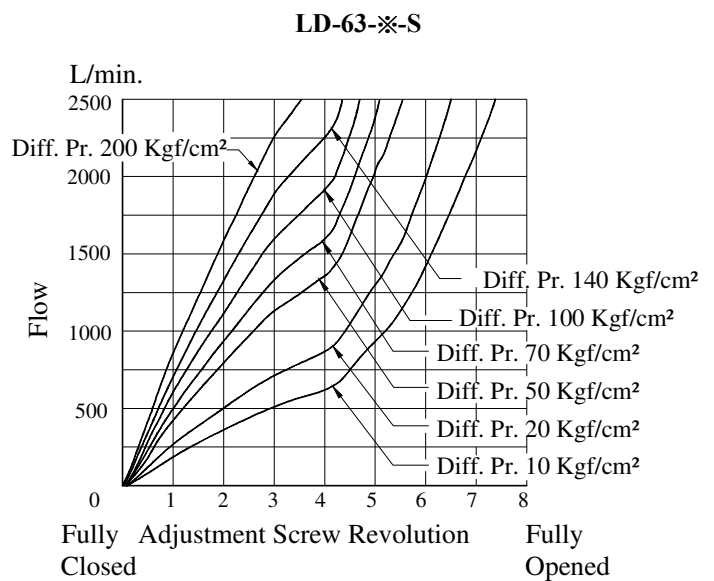
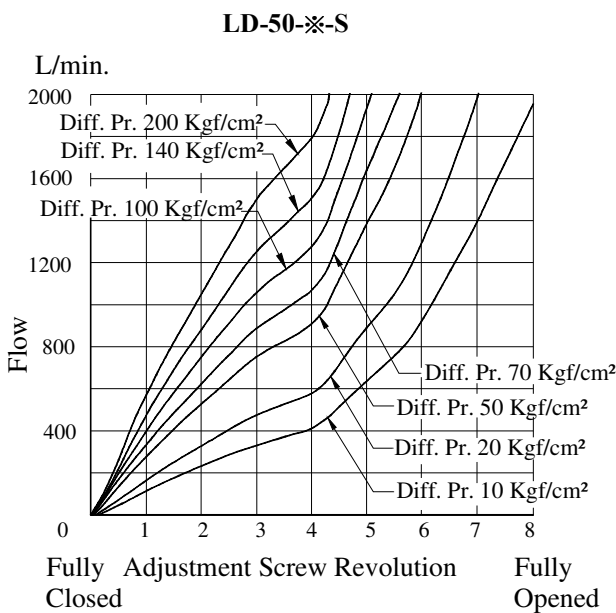
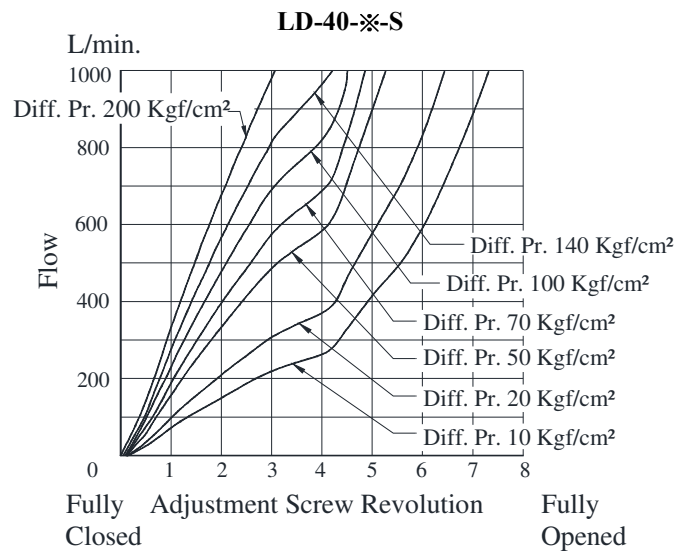
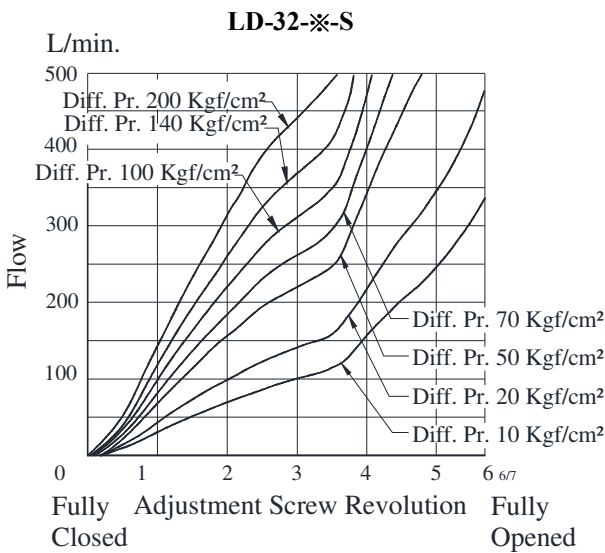
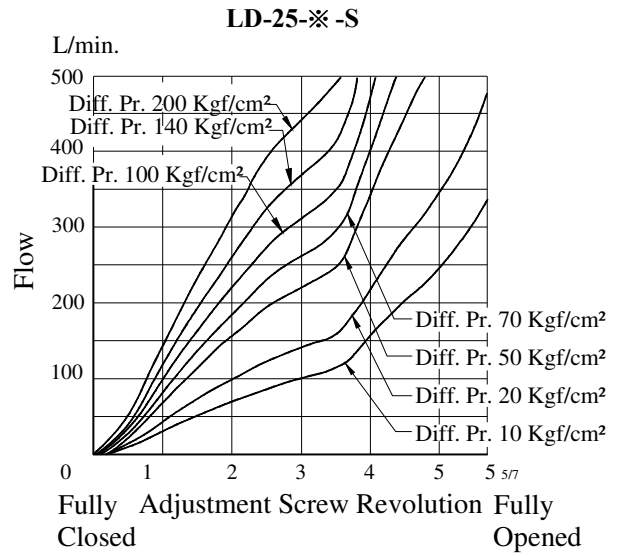
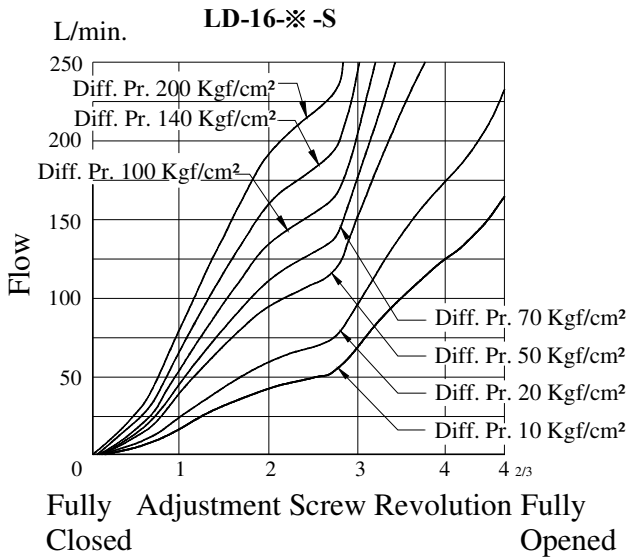

Relief Logic Valve

The relief logic valve is used to protect pumps and control valves from excessive pressure and controls the pressures of their hydraulic lines at constant levels.

With the help of vent lines, they are also capable of remote and unload control.



Specifications

Model Numbers	Max. operating Pressure Kgf/cm ²	Pressure Adj. Range Kgf/cm ²	Max. Flow* L/min.	Min. Flow L/min.	Mass Kg.
LB-16-※-※-10	315	4 - 315	125	5	3.6
LB-25-※-※-10			250	5	4.5
LB-32-※-※-11			500	8	6.7
LB-50-※-※-11			1200	10	16.1

* If the pressure is above 250 Kgf/cm², keep the flow rate above 15 L/min. for any model.

Model Number Designation

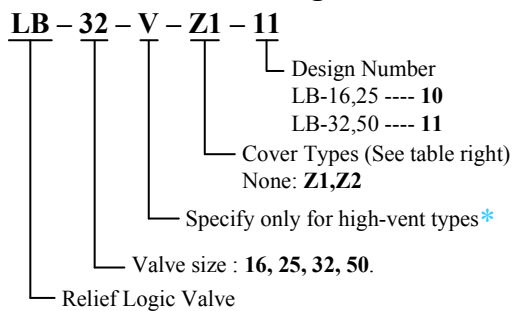

* Use high-vent pressure types if the shifting time from unloading to on-loading is reduced.

List of Cover Types

Cover Type Designation	Graphic Symbols	Valve Size			
		16	25	32	50
Standard (None)		O	O	O	O
Vent Controlled (Z1)		O	O	O	O
Vent Controlled (Z2)		O	O	O	O

Solenoid Controlled Relief Logic valves

The solenoid controlled relief logic valves are composite control valves having solenoid controlled directional and pilot relief valves and vent restrictors combined together.

This configuration eliminates pipes from the vent circuits of relief logic valves. They are used to put pumps in to unloading operation, with the solenoid controlled directional valves serving to select pilot lines, or to place hydraulic system two or three pressure controls, with the pilot relief valves in action.

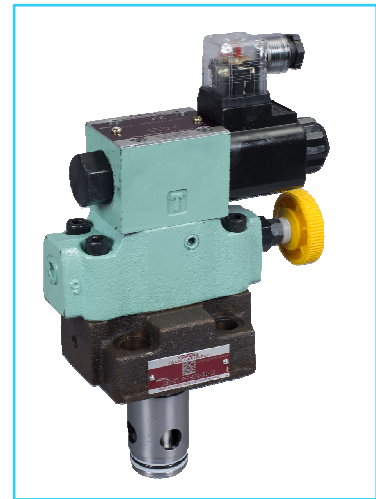

Specifications

Model Numbers	Max. operating Pressure Kgf/cm ²	Pressure Adj. Range Kgf/cm ²	Max. Flow L/min	Min. Flow* L/min	Mass Kg
LBS-16-※-※-12	315	4 - 315	125	5	8.8
LBS-25-※-※-12			250	5	9.7
LBS-32-※-※-12			500	8	11.9
LBS-50-※-※-12			1200	10	21.3

* If the pressure is above 250 Kgf/cm², keep the flow rate above 15 L/min for any model.

Model Number Designation

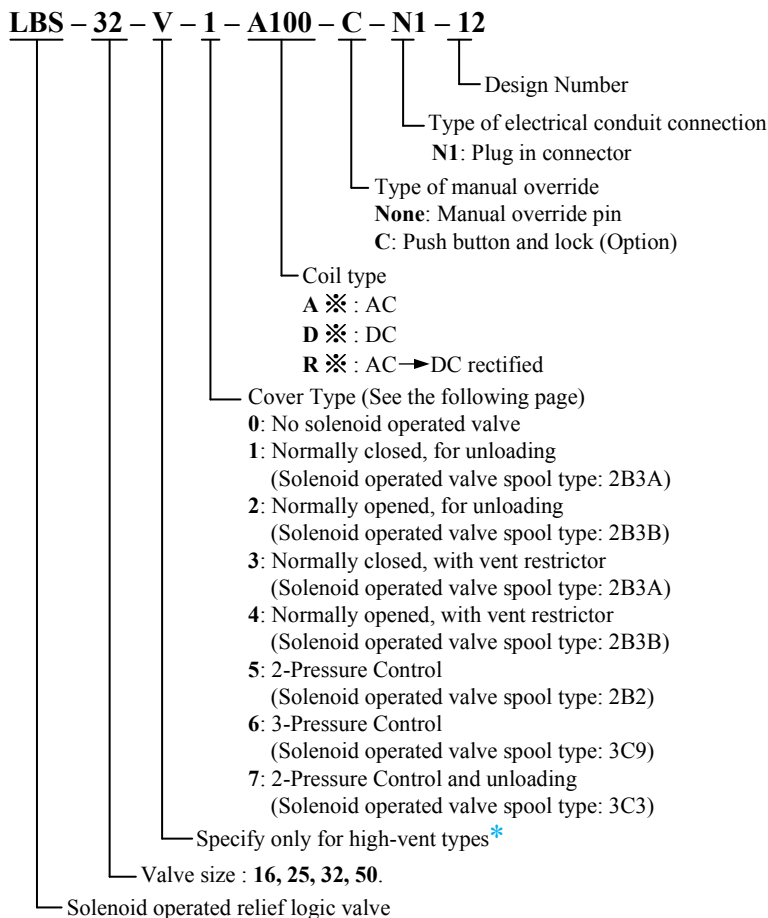

* Use high-vent pressure types if the shifting time from unloading to on-loading is reduced.

List of Cover Types

Cover Type Designation	Graphic Symbols	Valve Size				Cover Type Designation	Graphic Symbols	Valve Size			
		16	25	32	50			16	25	32	50
Without Solenoid valve (0)		O	O	O	O	Two Pressure control (5)		O	O	O	O
Normally Closed for Unloading (1)		O	O	O	O	Three Pressure Control (6)		O	O	O	O
Normally Open for Unloading (2)		O	O	O	O	Two-Pressure Control and Unloading (7)		O	O	O	O
Normally Closed with Vent Restrictor (3)		O	O	O	O						
Normally Open with Vent Restrictor (4)		O	O	O	O						

Typical Valve Characteristics Oil Viscosity 35 cSt [ISO VG 46, Temp 50° C]

Flow Rate Vs. Pressure

Hydraulic Fluid : ISO VG46 Oils
 Viscosity : 35 mm²/s (cSt)

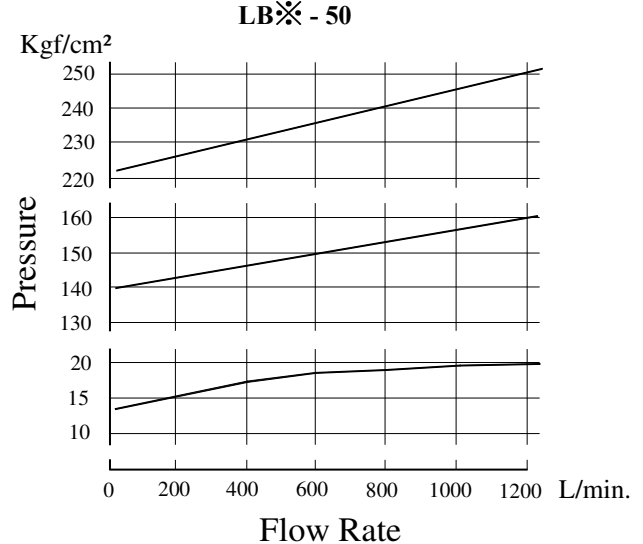
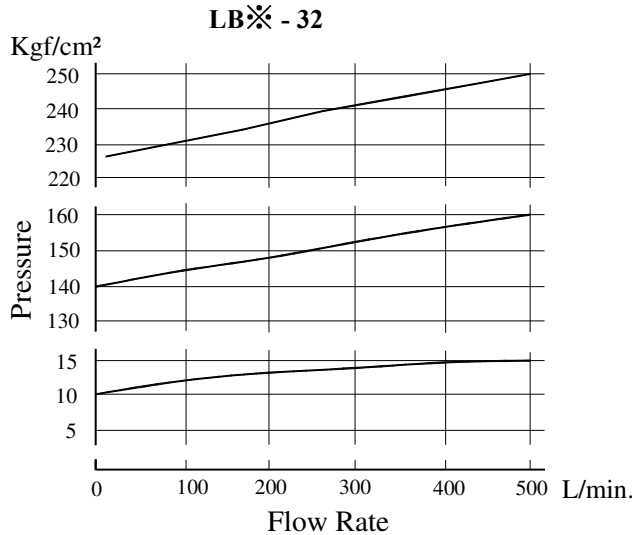
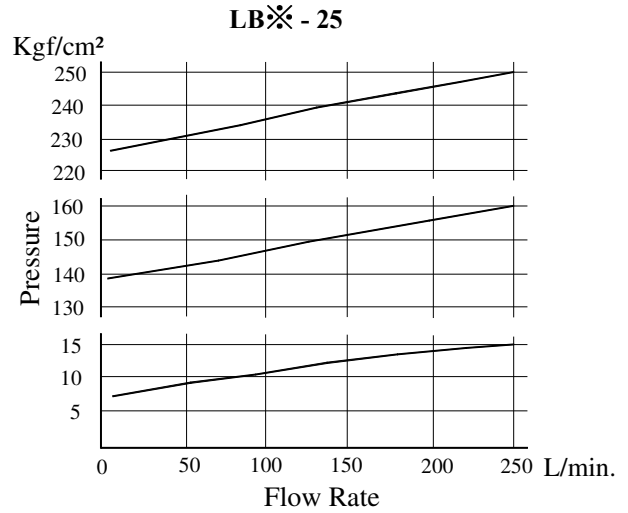
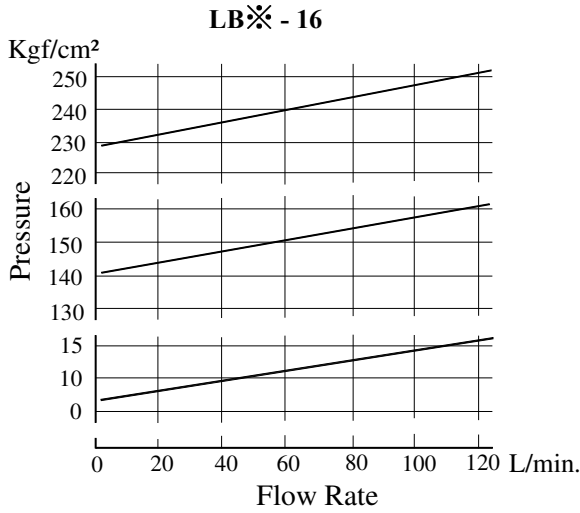

Min. Adjustment Pressure

Hydraulic Fluid : ISO VG46 Oils
 Viscosity : 35 mm²/s (cSt)

———— Low - Vent
 - - - - - High - Vent

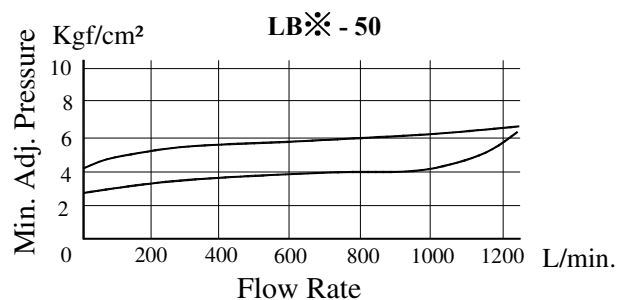
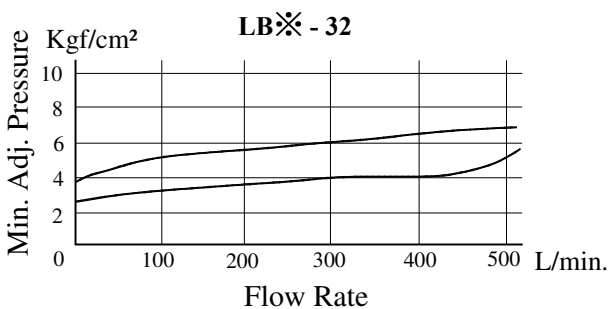
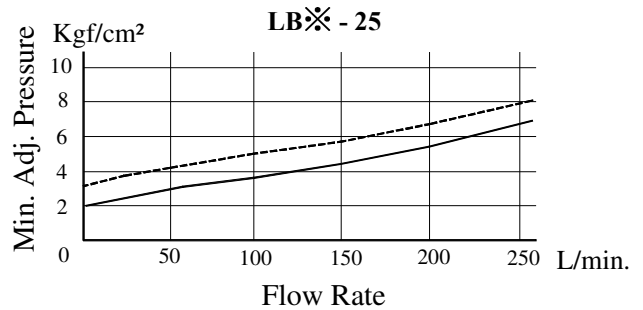
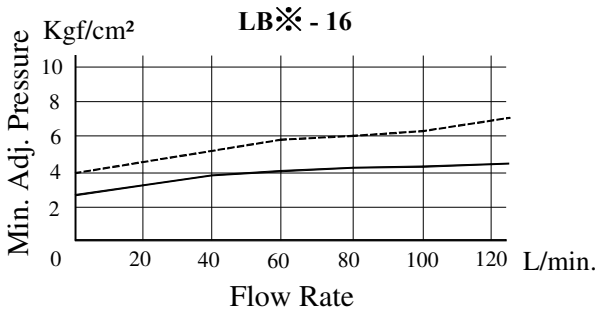

Relief Logic Valves

Solenoid Controlled Relief Logic Valves

Mounting Dimensions

The mounting dimensions of Yuken Logic valves confirm to the cavity specifications comply with ISO 7368 (TWO-PORT SLIP-IN CARTRIDGE VALVES-CAVITIES).

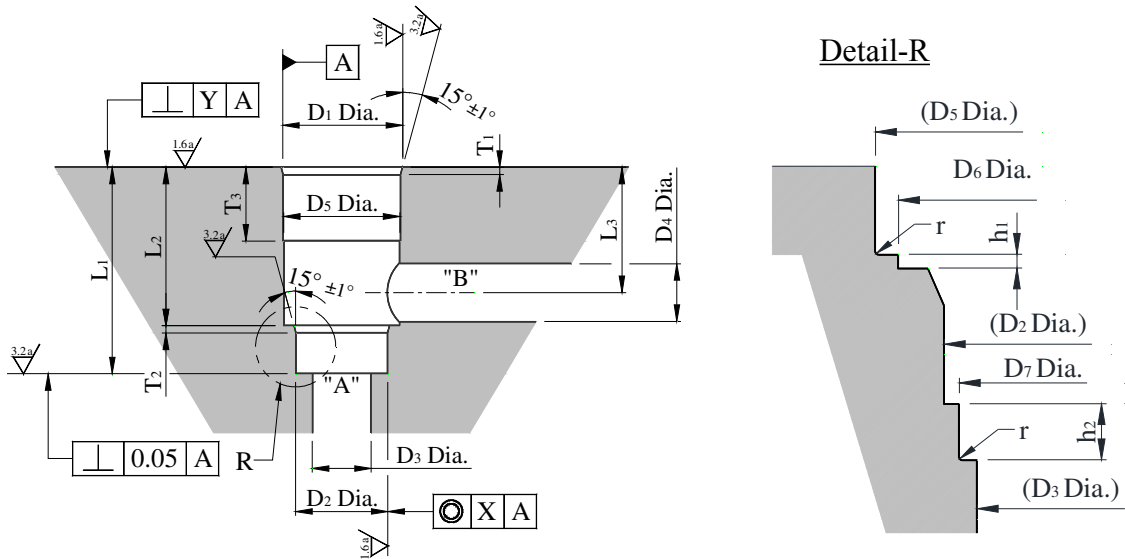

Valve Size	L1		L2		L3 ±0.3	D1		D2		D3	D4	D5 Min.
	Standard Dimensions	Tolerance	Standard Dimensions	Tolerance		Standard Dimensions	Tolerance	Standard Dimensions	Tolerance			
16	56	+ 0.1 0	43	+ 0.1 0	34	32	+ 0.039 0	25	+ 0.033 0	16	31.5	
25	72		58		44	45	34	+ 0.039 0	25	44.5		
32	85		70		52	60	45	+ 0.046 0	40	59.5		
40	105		87		64	75	55	+ 0.046 0	40	74		
50	122		100		72	90	68	+ 0.054 0	50	89		
63	155		130		95	120	90	+ 0.054 0	63	119		

Valve Size	D6	D7 Min.	T1	T2	T3 +0.5 0	h1	h2	r Max.	x	y
16	28.5	24.6	2	2	20	0.2	2	0.8	0.03	0.05
25	39.5	33.6	2.5	2.5	30		3		0.05	
32	52.5	44.6	2.5	2.5	30		5			
40	65	54.6	3	3	30	0.3	5	0.05	0.1	
50	75	67.6	3	3	35					
63	105	89.6	4	4	40					

Cover Mounting Dimensions -

Square Type Flange Cover

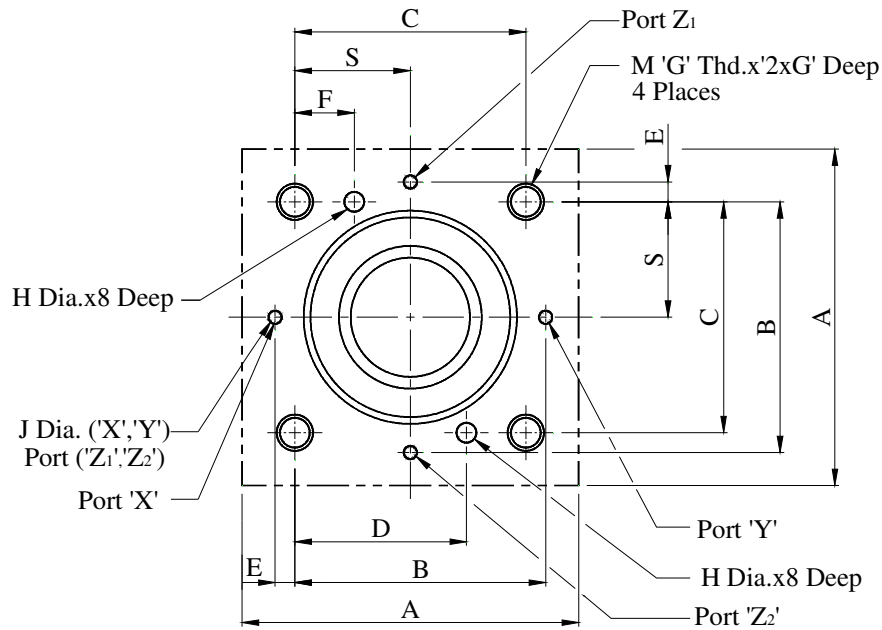

Valve Size	A ^{*1} +1 0	B ± 0.2	C ± 0.2	S ± 0.2	E ± 0.2	F ± 0.2	G	H ² Dia.	J ³ Dia.	D ± 0.2
16	65	48	46	23	2	12.5	8	4	4	-
LDS-16-H01	65	48	46	23	2	-	8	4	4	33.5
25	85	62	58	29	4	13	12	6	6	-
32	102	76	70	35	6	18	16	6	8	-
40	125	92.5	85	42.5	7.5	19.5	20	6	10	-
50	140	108	100	50	8	20	20	8	10	-
63	180	137.5	125	62.5	12.5	24.5	30	8	12	-

- * 1 The tolerances in column A apply to cutting.
- * 2 H Dia. and J Dia. are drilled holes.
- * 3 J Dia. should be drilled appropriately for X,Y,Z₁, or Z₂

Mounting Bolt Tightening Torques

Sl. No.	Size	Tightening Torque Kgf-cm
1	M8	365.0
2	M12	1235.0
3	M16	3010.0
4	M20	5860.0
5	M30	16800.0