

PV2R Series Single Vane Pumps

These pumps have been developed especially for low noise operation. To comply with a wide range of applications for instance the injection moulding machine. PV2R Series Single Pumps provide wide range of delivery volume [5.8-237.0 cm³/rev.] for the pumps.

The main internal spare parts of the pumps are built in as cartridge kit.

Therefore, the replacement can be easily done by simply changing the cartridges.

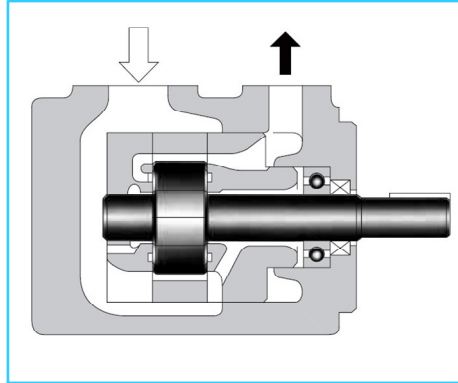
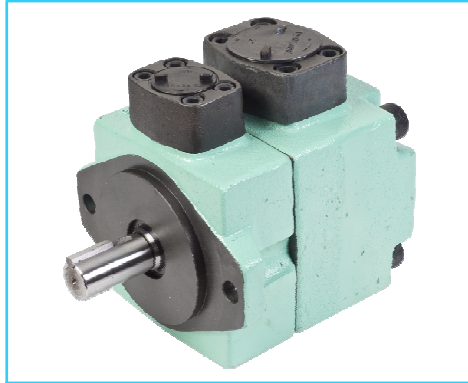

Graphic Symbol

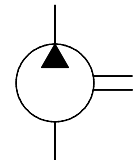

Specifications

Model Number	Geometric Displacement cm ³ /rev.	Max. Operating Pressure Kg/cm ²							Output Flow & Input Power	Shaft Speed Range r/min.	
		Petroleum Based Oils			Water Containing Fluids			Synthetic Fluids		Max.	Min.
		Specially Specified ^{*6}	Antiwear Type	R & O Type	Antiwear Type ^{*6} Water Glycols	Water Glycols	Water in Oil Emulsions	Phosphate Esters			
PV2R1 - 6	5.8	210 ^{*5}	175 ^{*5}	160	160	70	70	160	Refer Page 154, 155 & 156	1800 ^{*3} (1200)	750 ^{*4}
PV2R1 - 8	8.0										
PV2R1 - 10	9.4										
PV2R1 - 12	12.2										
PV2R1 - 14	13.7										
PV2R1 - 17	16.6										
PV2R1 - 19	18.6										
PV2R1 - 23	22.7										
PV2R1 - 25	25.3	160	160								
PV2R2 - 26	26.6	210	175	140	160	70	70	140	Refer Page 156, 157 & 158	1800 ^{*3} (1200)	600 ^{*4}
PV2R2 - 33	33.3										
PV2R2 - 41	41.3										
PV2R2 - 47	47.2										
PV2R2 - 53	52.5										
PV2R2 - 59	58.2										
PV2R2 - 65	64.7										
PV2R3 - 52	52.2	210	175	140	160	70	70	140	Refer Page 158 & 159	1800 ^{*3} (1200)	600
PV2R3 - 60	59.6										
PV2R3 - 66	66.3										
PV2R3 - 76	76.4										
PV2R3 - 94	93.6										
PV2R3 - 116	115.6	160	160						1800 ^{*1} (1200) ^{*3}		
PV2R4 - 136	136	175	175	140	160	70	70	140	Refer Page 159 & 160	1800 ^{*2} (1200) ^{*3}	600
PV2R4 - 153	153										
PV2R4 - 184	184										
PV2R4 - 200	201										
PV2R4 - 237	237										

*1 If PV2R3 - 116 is used at speed above 1700 r/min. the suction pressure is limited to 0 Kg/cm².
 *2 If PV2R4 - 237 is used at speed above 1700 r/min. the suction pressure is limited to 0.13 Kg/cm²
 *3 If phosphate ester or water containing fluids are used, the maximum speed is limited to 1200 r/min.
 *4 For starting at low speed, the maximum viscosity is limited. For details, see Hydraulic Fluids.
 *5 For pressure above 160 Kg/cm² raise the speed over 1450 r/min.
 *6 For the brands of 'Antiwear type water glycol' and 'Specially specified' petroleum based oils see the 'Hydraulic Fluids' in EIC-N-1001.

Model Number Designation

F-	PV2R1	-6	-L	-R	A	A	-43
Special Seals	Series Number	Nominal Displacement	Type of Mounting	Shaft * Rotation	Discharge Port Position	Suction Port Position	Design Number
				As Viewed from Shaft End			
F: For Phosphate Ester Type Fluids (Omit if not required)	PV2R1	6, 8 10, 12 14, 17 19, 23 25, 31	L: Foot Mounting	R: Clockwise (Normal)	A: Upward (Normal) B: Bottom R: Right L: Left	A: Upward (Normal) B: Bottom R: Right L: Left	43
	PV2R2	26, 33 41, 47 53, 59 65					40
	PV2R3	52, 60 66, 76 94, 116	F: Flange Mounting				31
	PV2R4	136, 153 184, 200 237					30

* Available to supply pump with anti-clockwise rotation. Consult Yuken for details.

* For instructions regarding changing the port positions, consult YUKEN INDIA LTD.

Pipe Flange kits

Pipe flange Kits are available. When ordering, specify kits from the table below.

Pump Model Number	Name of Port	Pipe Flange Kit Numbers
		Threaded Connection
PV2R1	Suction	F5-08-A-1080
	Discharge	F5-04-A-1080
PV2R2	Suction	F5-10-A-1080
	Discharge	F5-06-A-1080
PV2R3	Suction	F5-16-A-1080
	Discharge	F5-10-A-1080
PV2R4	Suction	-----
	Discharge	F5-12-A-1080

Note: Special seals (Viton Seals) are required when phosphate ester type fluids are used. (Prefix “F” before model code of pipe flange kit numbers when ordering).

Mass

Model Number	Mass Kg.	
	Flange Mtg.	Foot Mtg.
PV2R1	9.0	11.2
PV2R2	19.0	23.3
PV2R3	36.7	46.7
PV2R4	68.5	93.5

PV2R1-※-F-RAA-43

● **Flange Mounting**

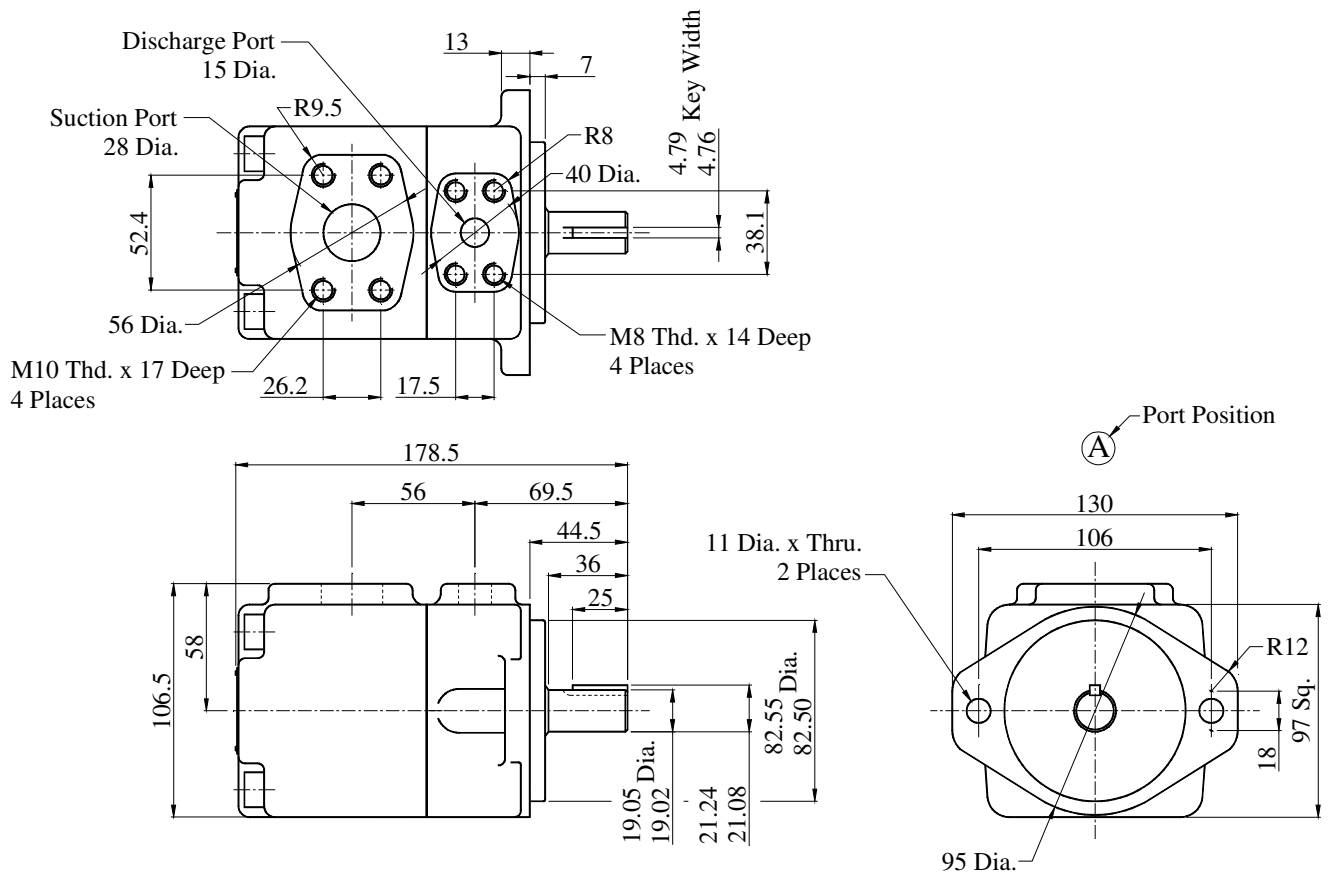

DIMENSIONS IN MILLIMETRES

PV2R1-※-L-RAA-43

● **Foot Mounting**

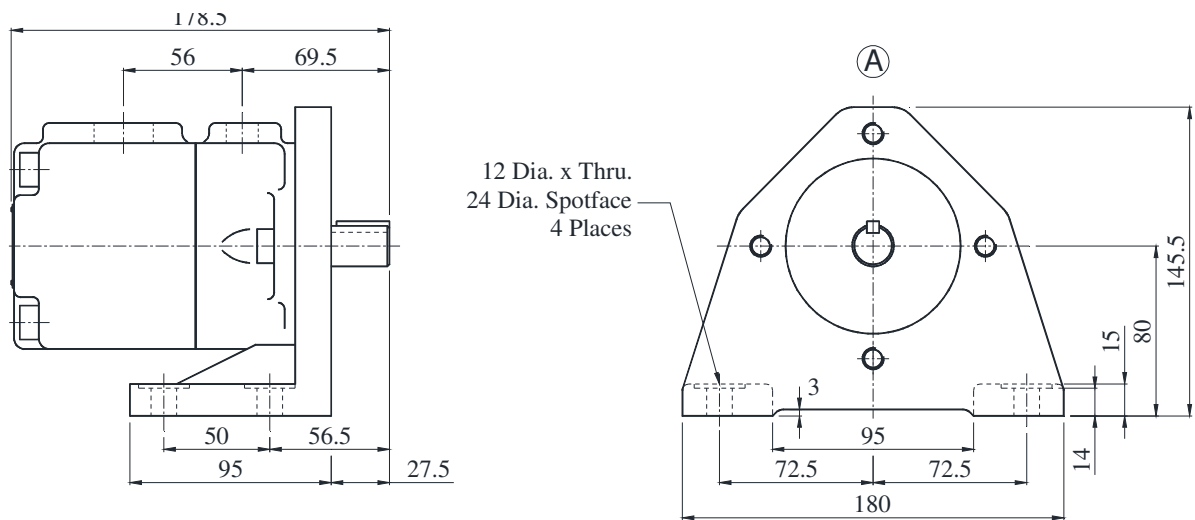

● For other dimensions, refer to “Flange Mtg”.

PV2R2-※-F-RAA-40

● **Flange Mounting**

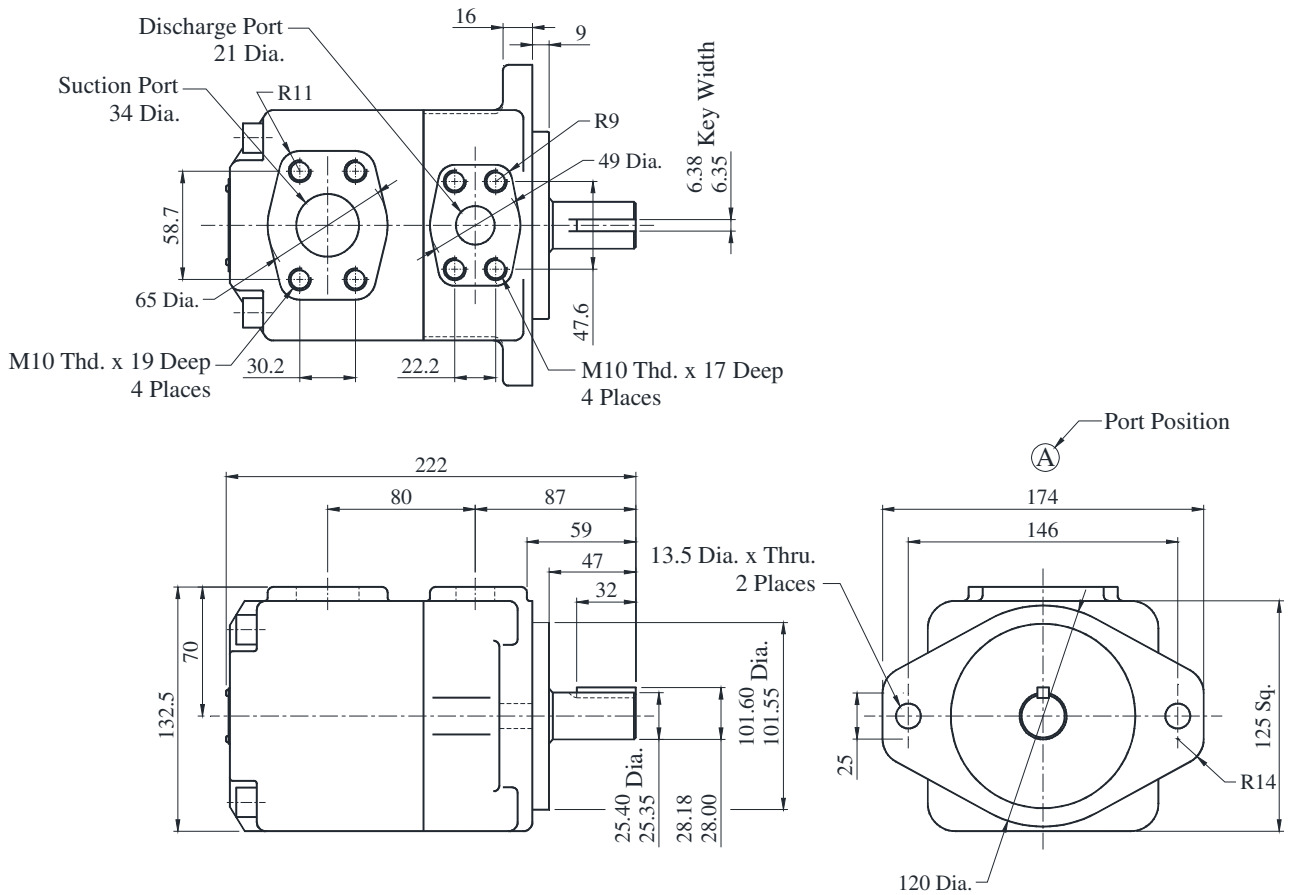

DIMENSIONS IN MILLIMETRES

PV2R2-※-L-RAA-40

● **Foot Mounting**

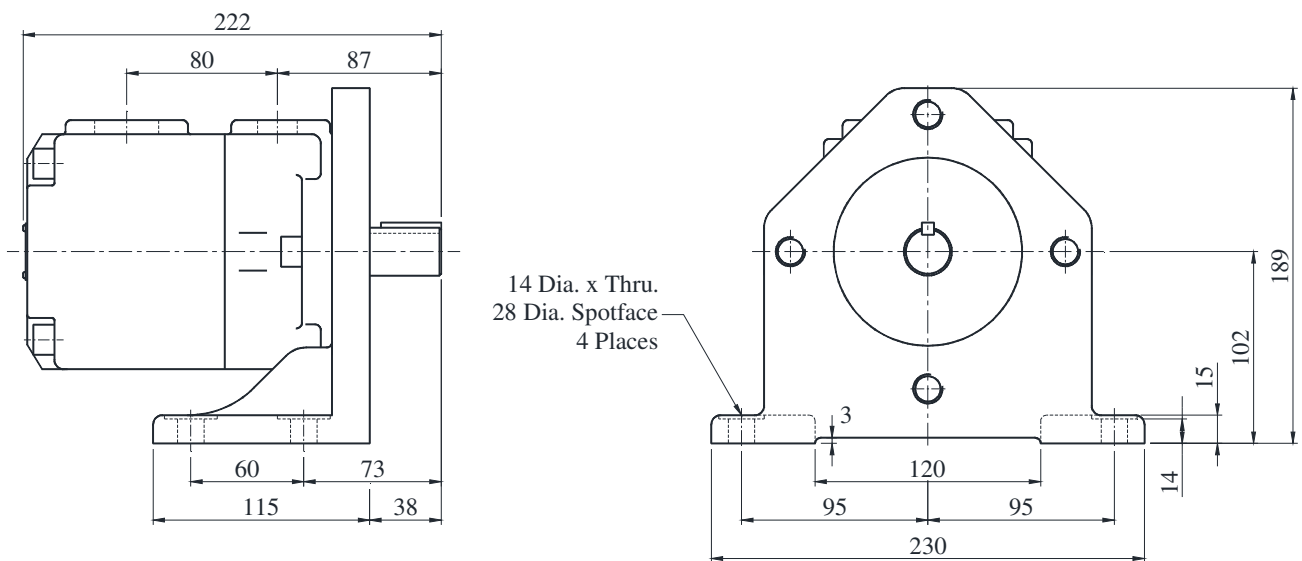

● For other dimensions, refer to “Flange Mtg”.

■ PV2R3-※-F-RAA-31

● Flange Mounting

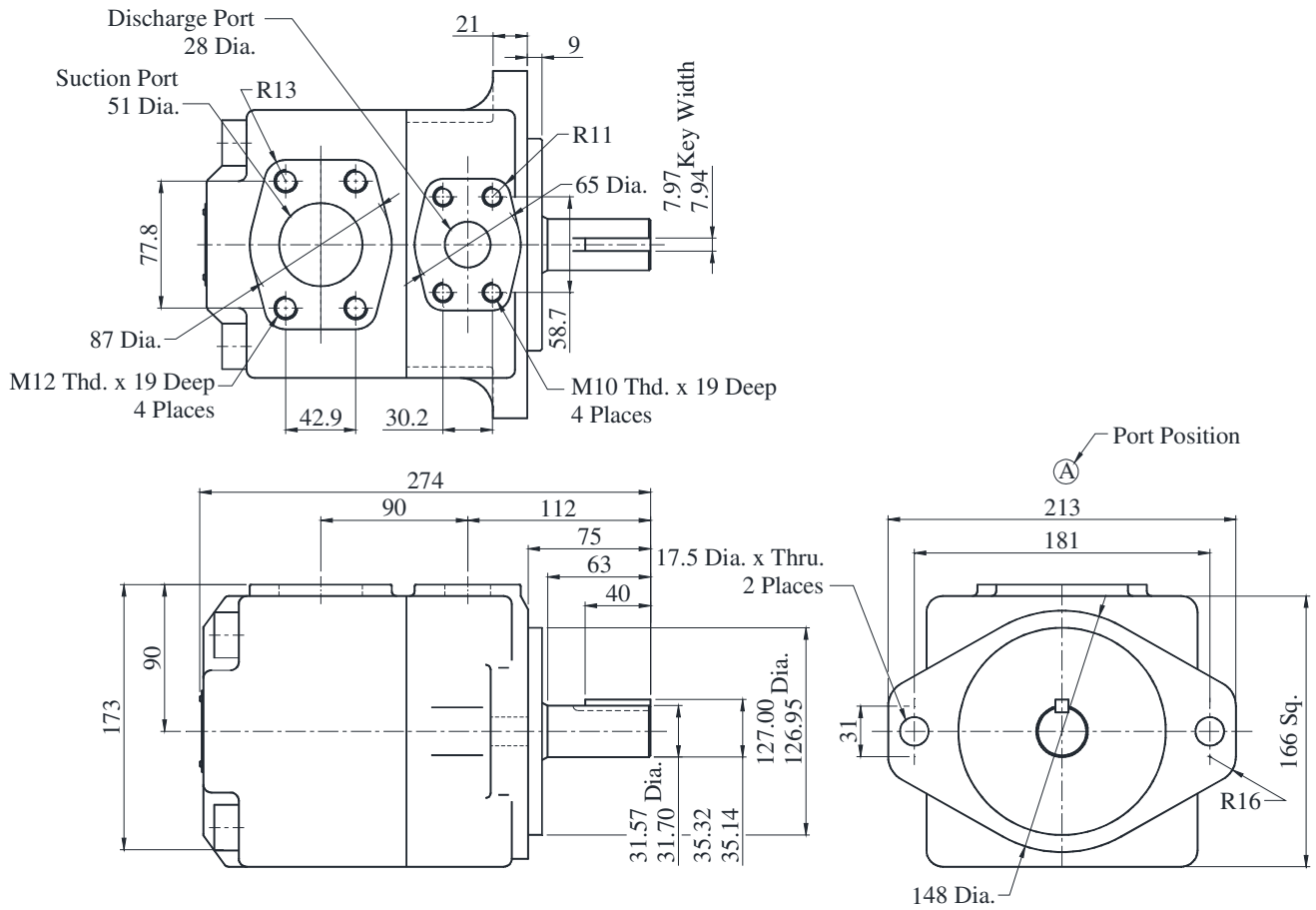

DIMENSIONS IN MILLIMETRES

■ PV2R3-※-L-RAA-31

● Foot Mounting

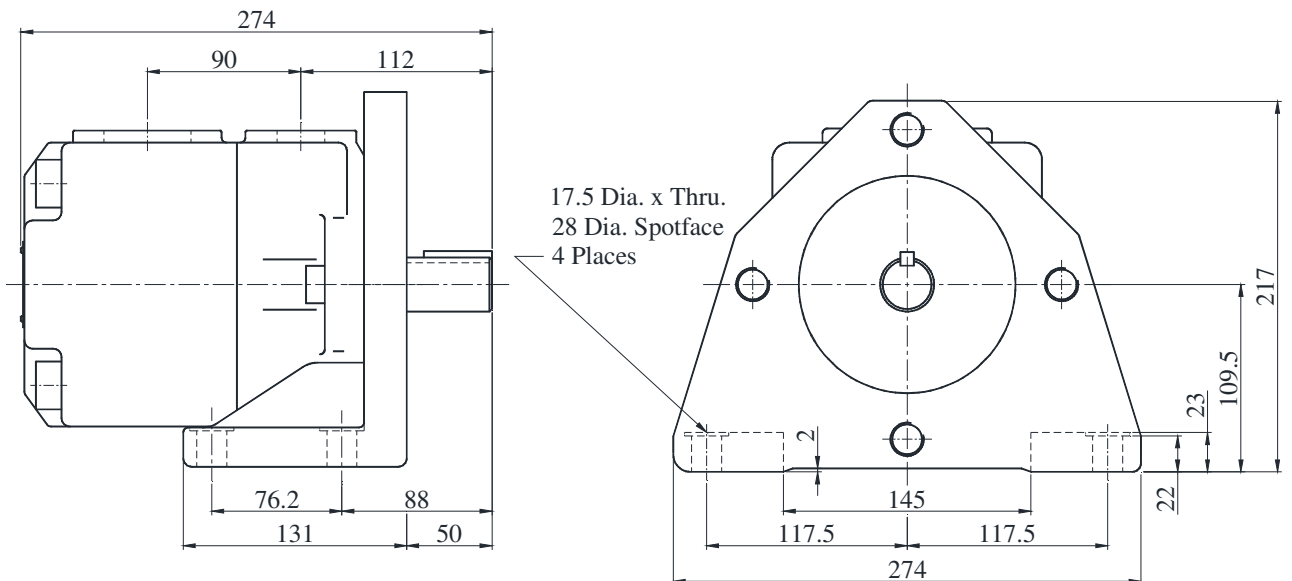

● For other dimensions, refer to “Flange Mtg”.

PV2R4-※-F-RAA-30

● **Flange Mounting**

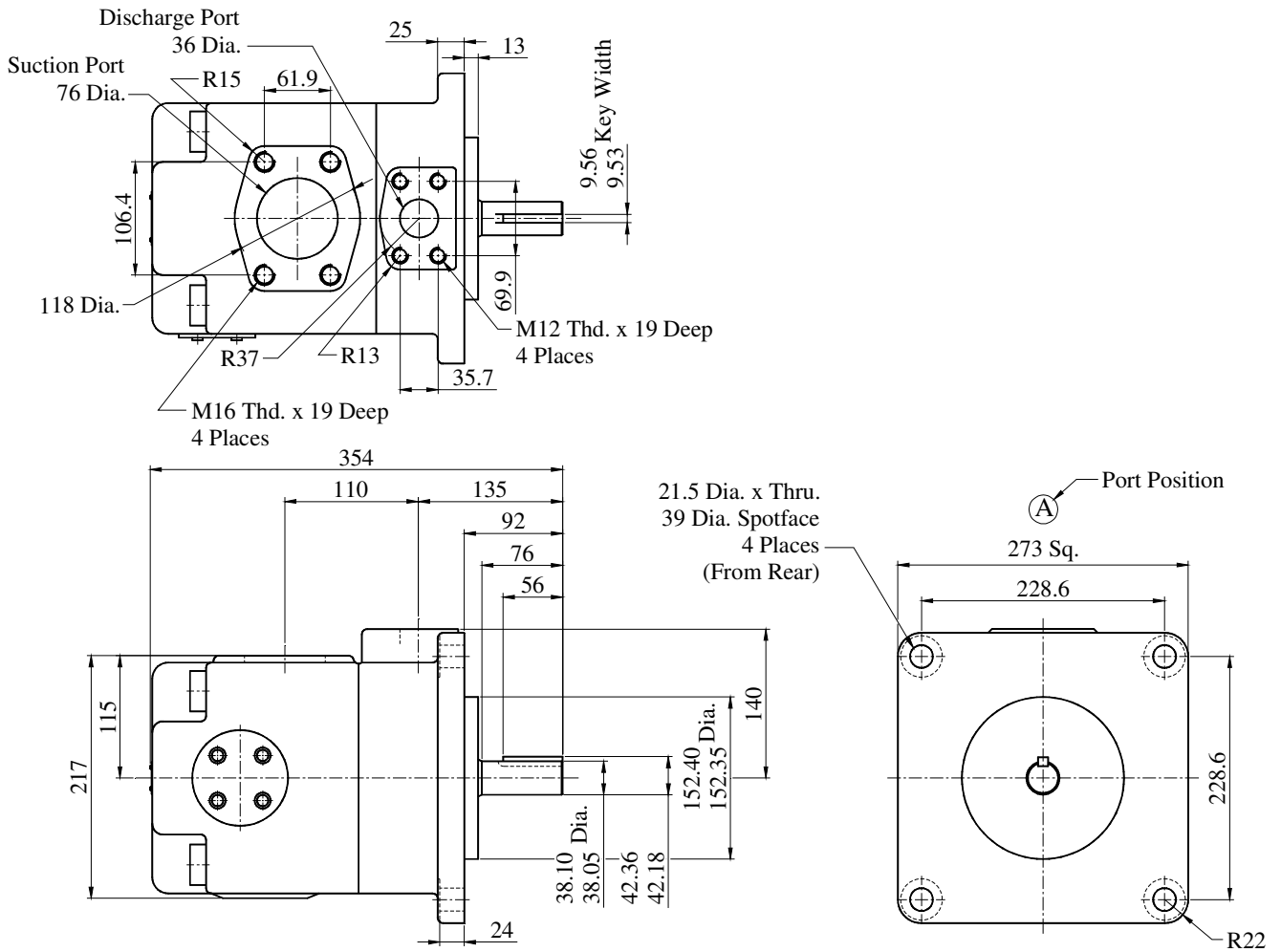

DIMENSIONS IN MILLIMETRES

PV2R4-※-L-RAA-30

● **Foot Mounting**

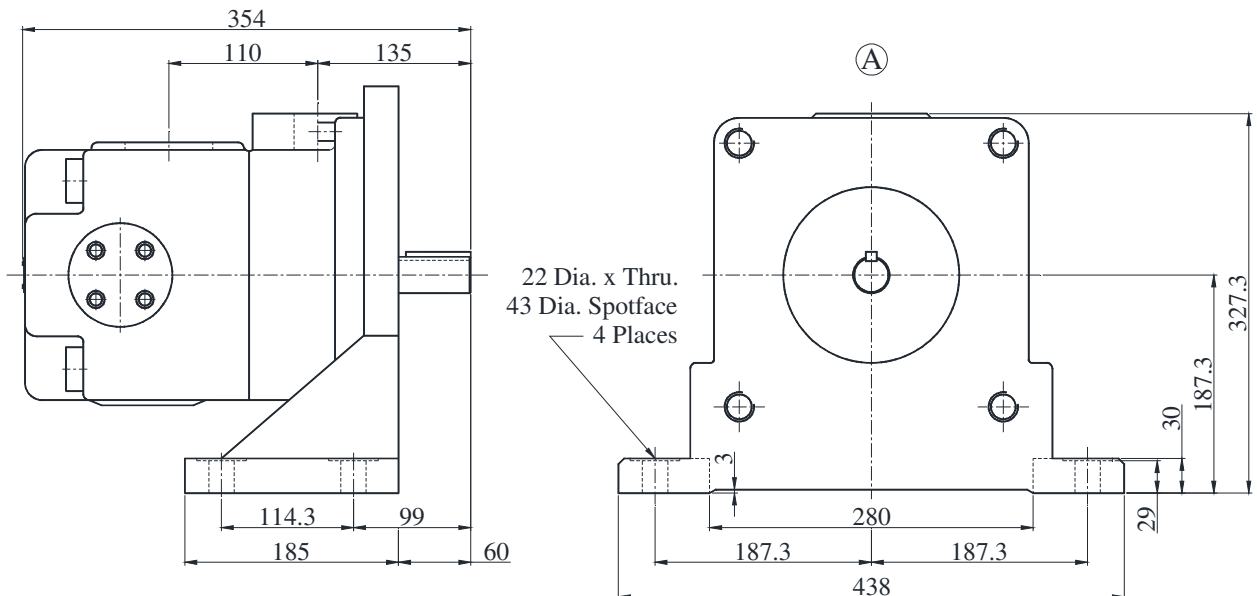

● For other dimensions, refer to “Flange Mtg”.

Noise Level

● **Measuring Conditions**

Fluid viscosity :20cSt

Measurement Point :One Meter horizontally away from head cover

Background Noise :40dB(A)

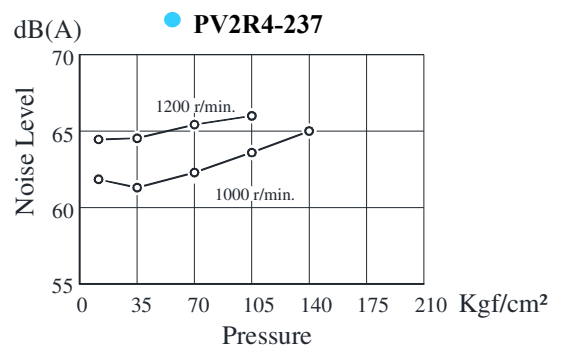
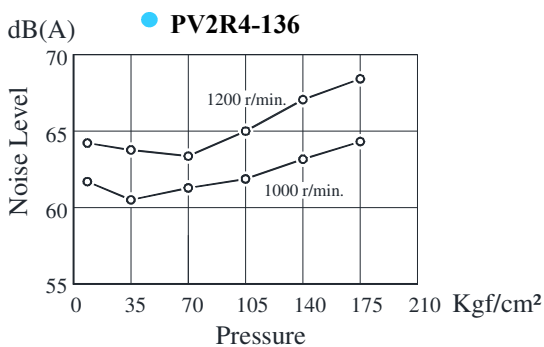
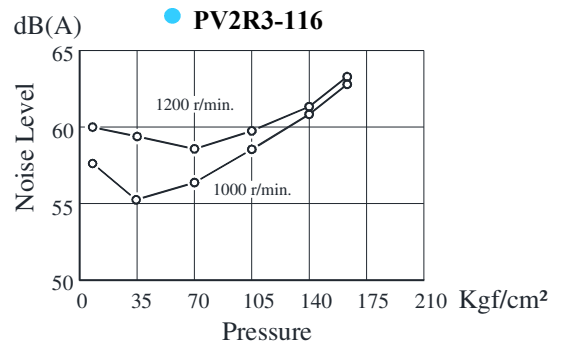
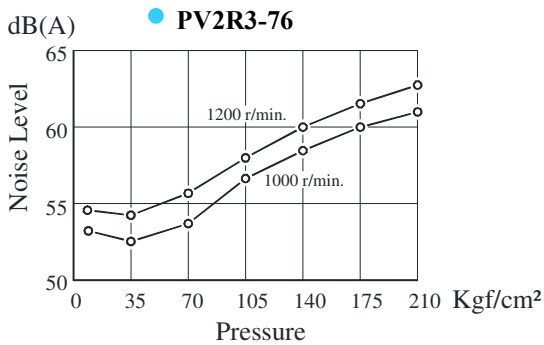
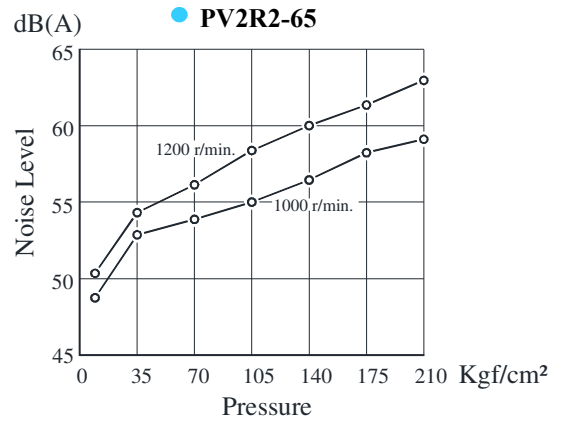
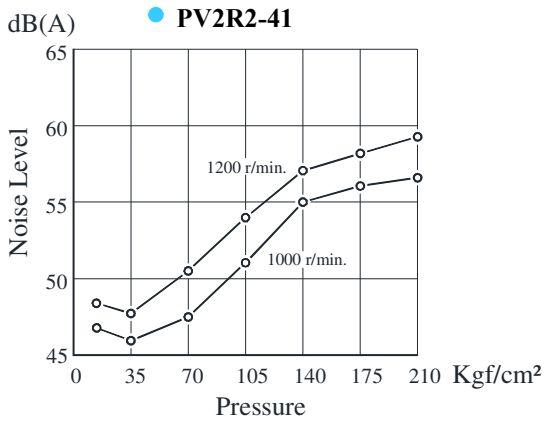
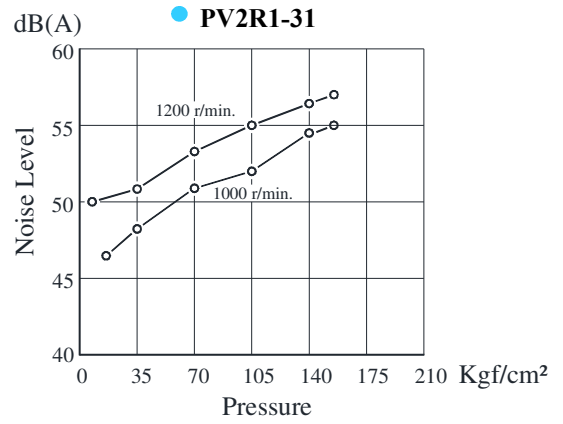
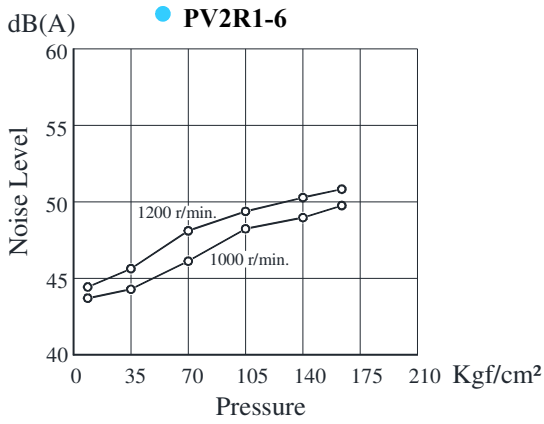

Typical Pump Characteristics Oil Viscosity 20 cSt [ISO VG 32, 50⁰C]

● PV2R1-6

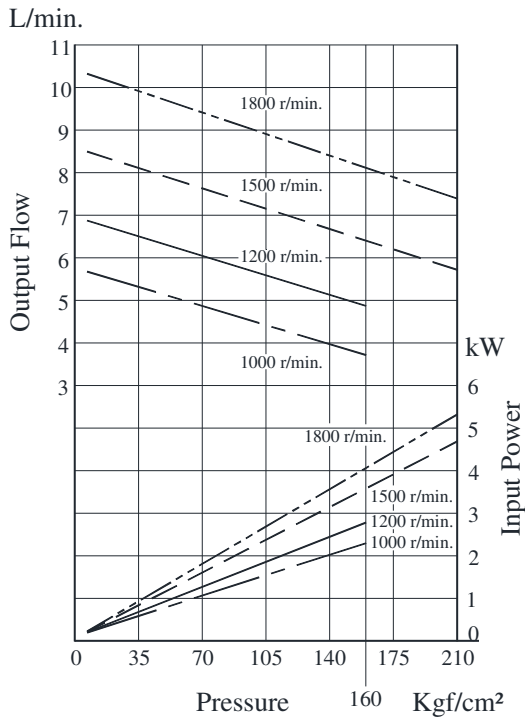

● PV2R1-8

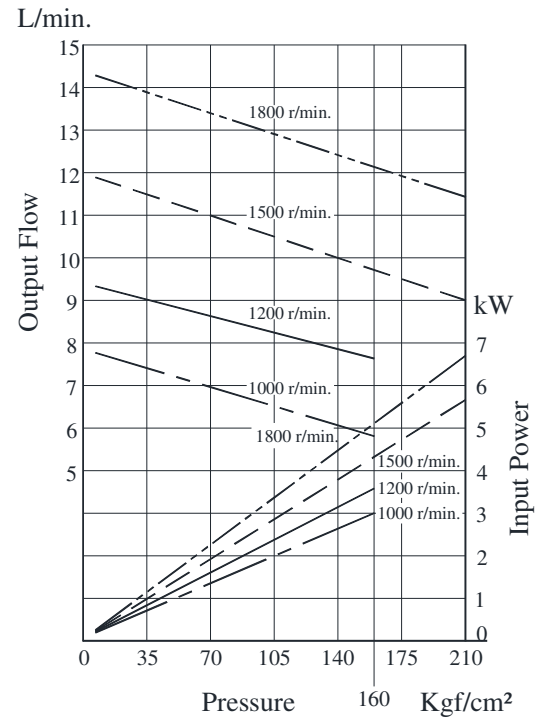

● PV2R1-10

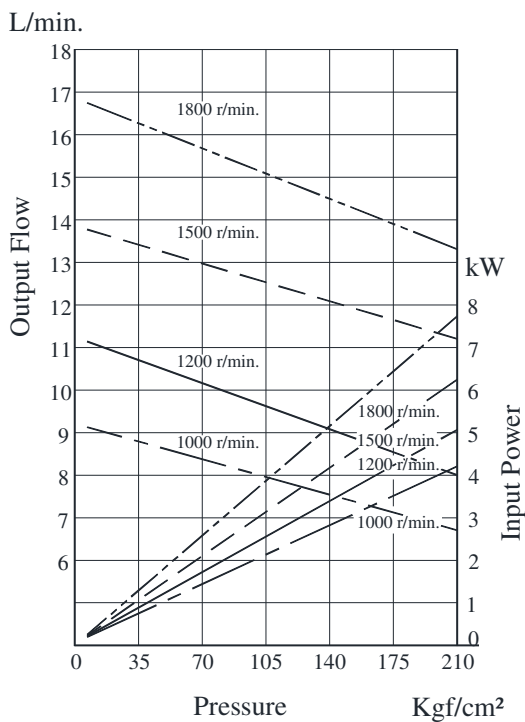

● PV2R1-12

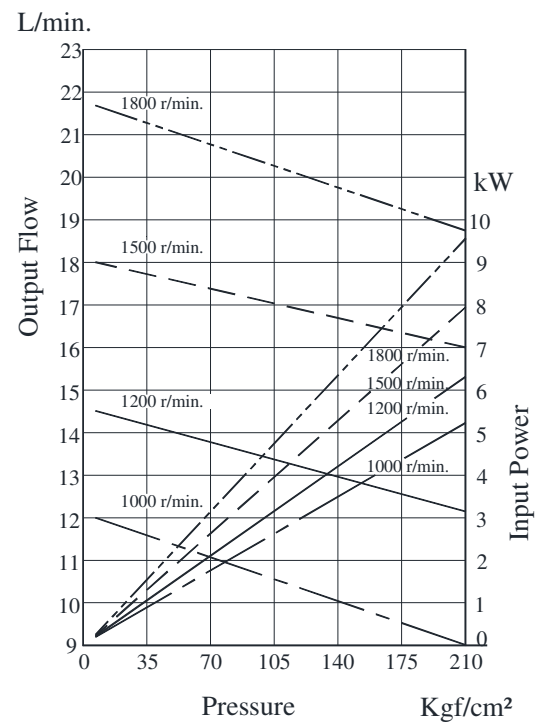

Typical Pump Characteristics Oil Viscosity 20 cSt [ISO VG 32, 50°C]

● PV2R1-14

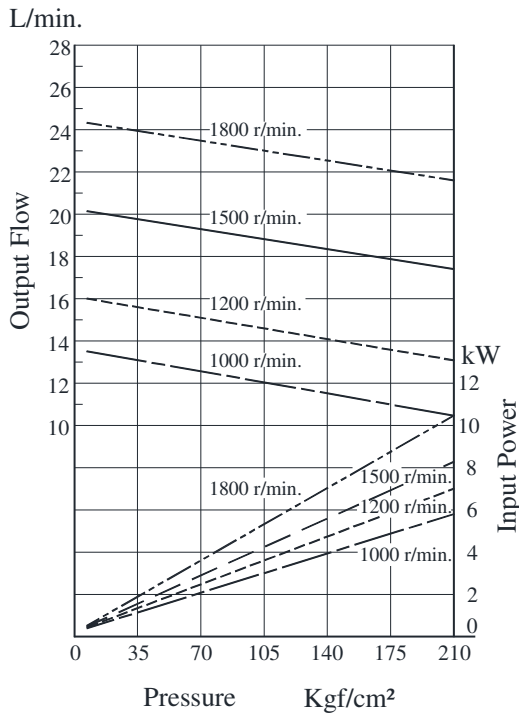

● PV2R1-17

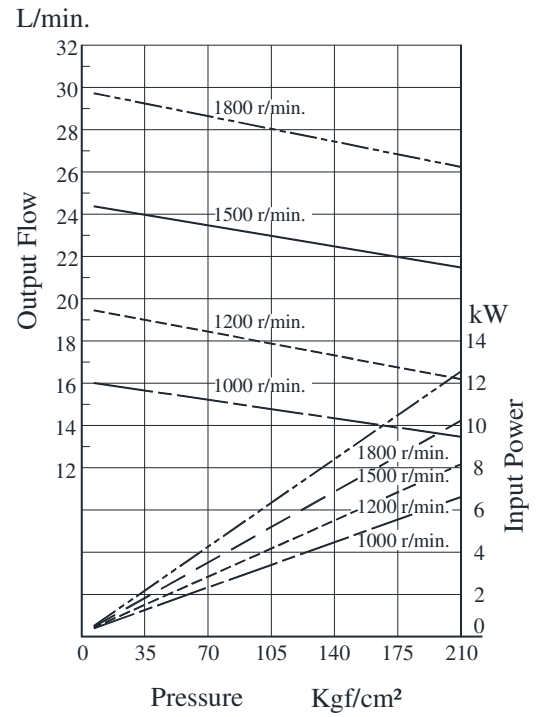

● PV2R1-19

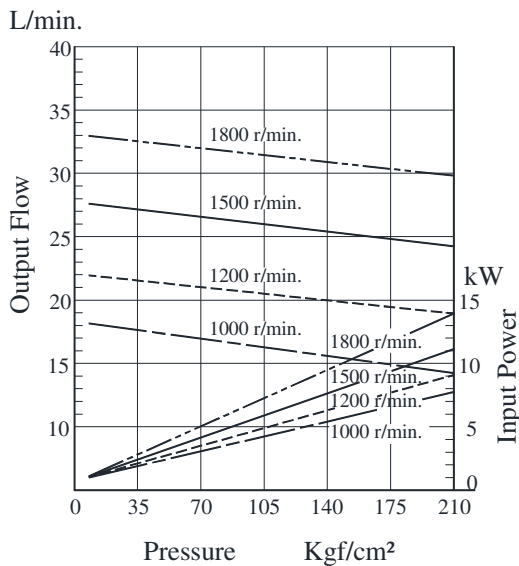

● PV2R1-23

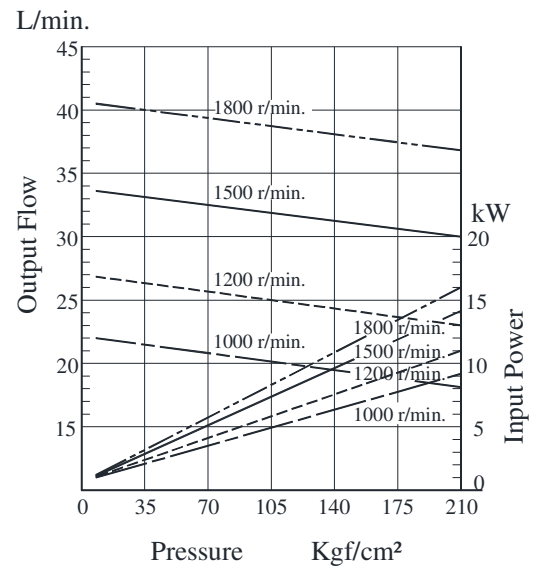

B
PV2R Series
Single Vane Pumps

Typical Pump Characteristics Oil Viscosity 20 cSt [ISO VG 32, 50°C]

● **PV2R1-25**

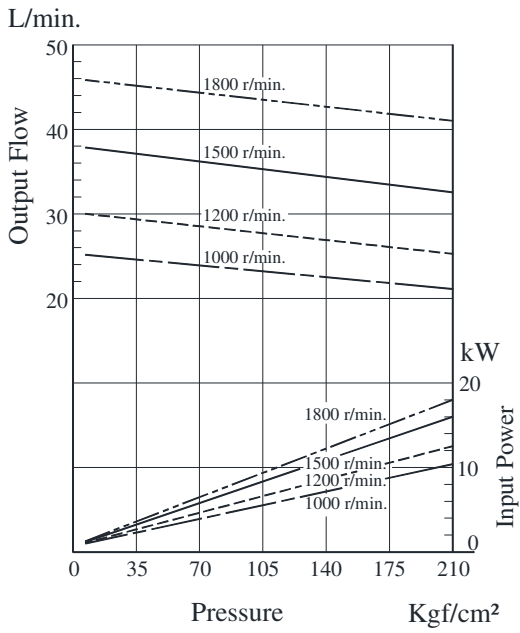

● **PV2R1-31**

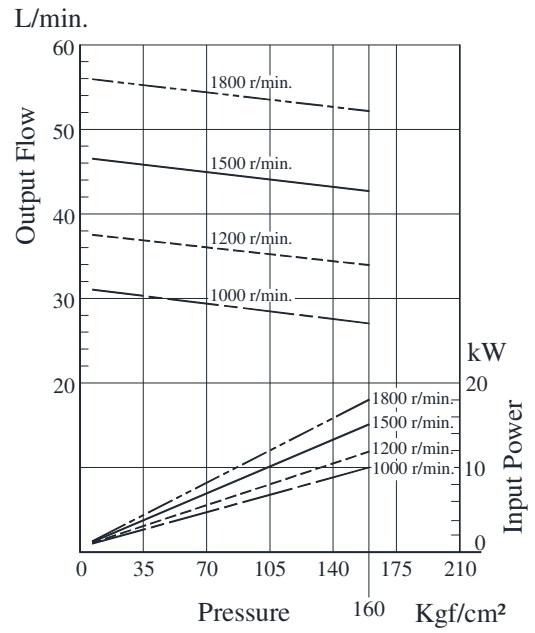

● **PV2R2-26**

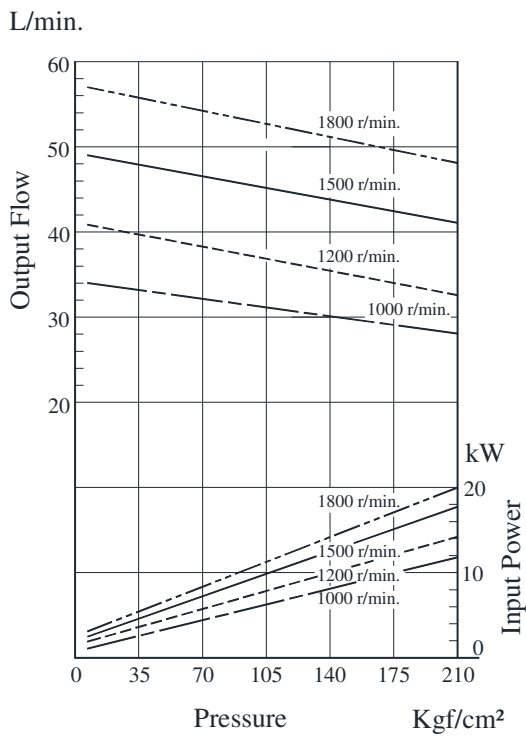

● **PV2R2-33**

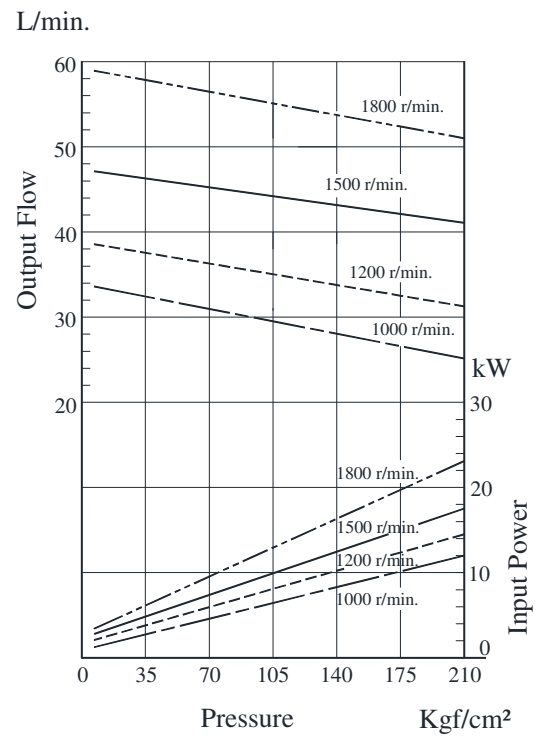

Typical Pump Characteristics Oil Viscosity 20 cSt [ISO VG 32, 50⁰C]

● PV2R2-41

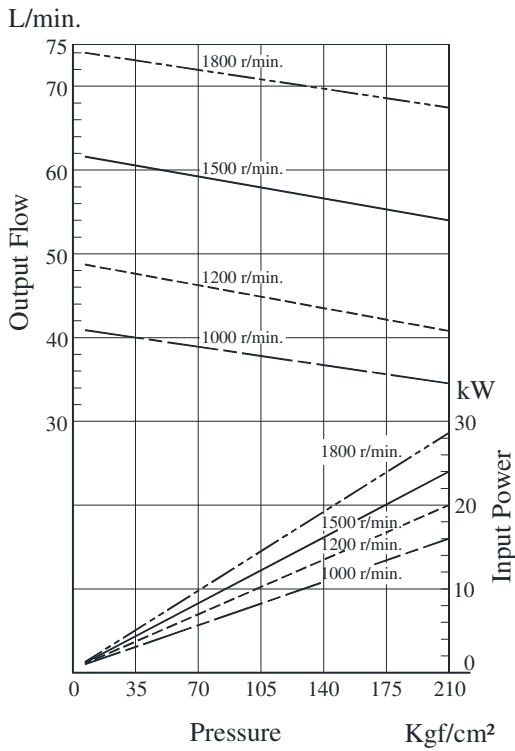

● PV2R2-47

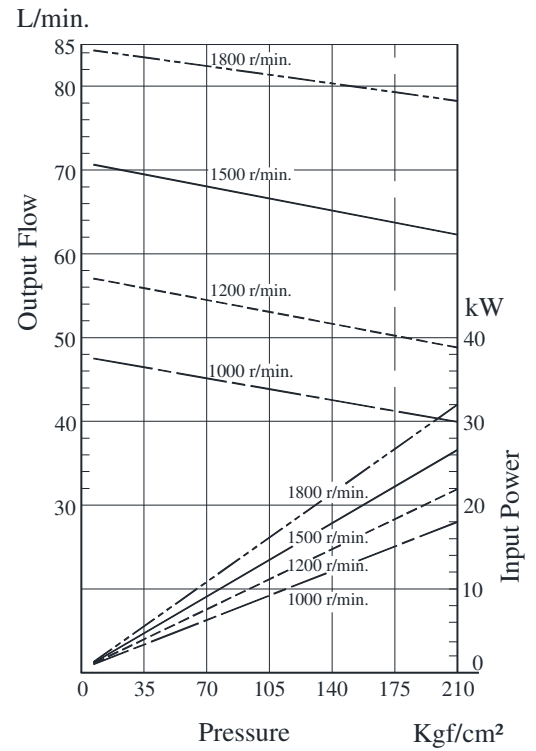

● PV2R2-53

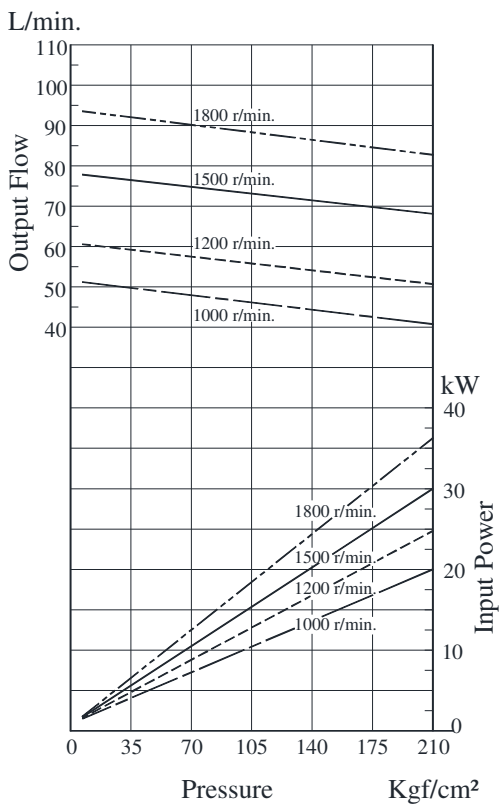

● PV2R2-59

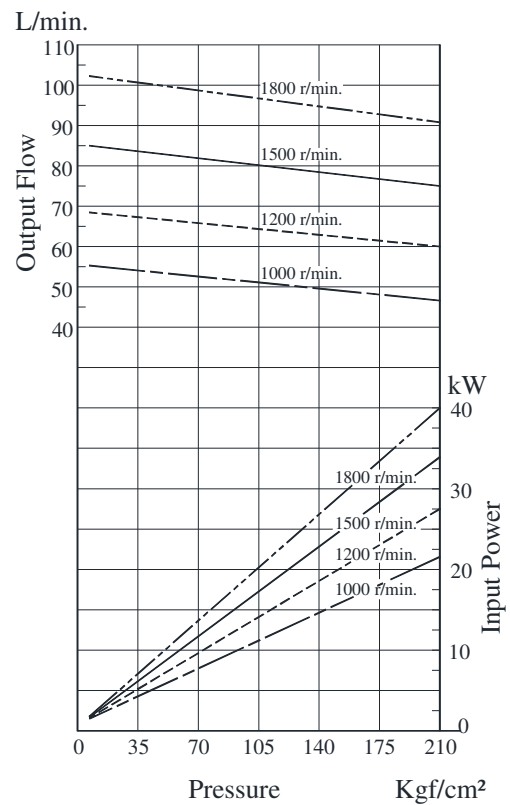

Typical Pump Characteristics Oil Viscosity 20 cSt [ISO VG 32, 50°C]

● **PV2R2-65**

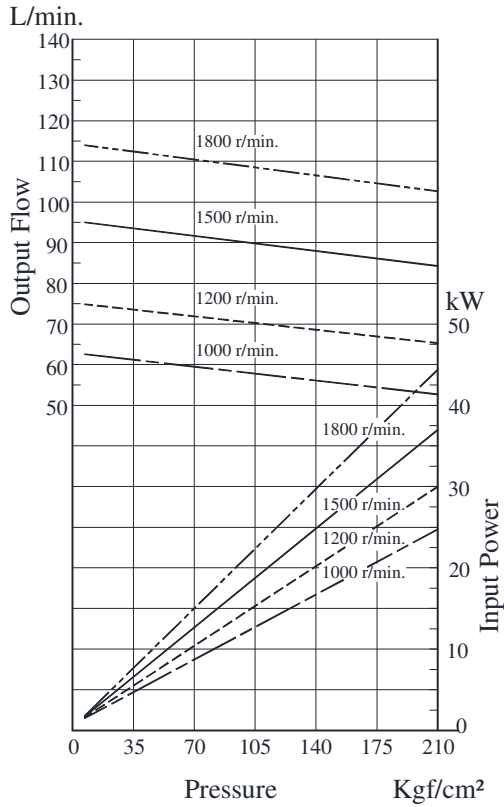

● **PV2R3-52**

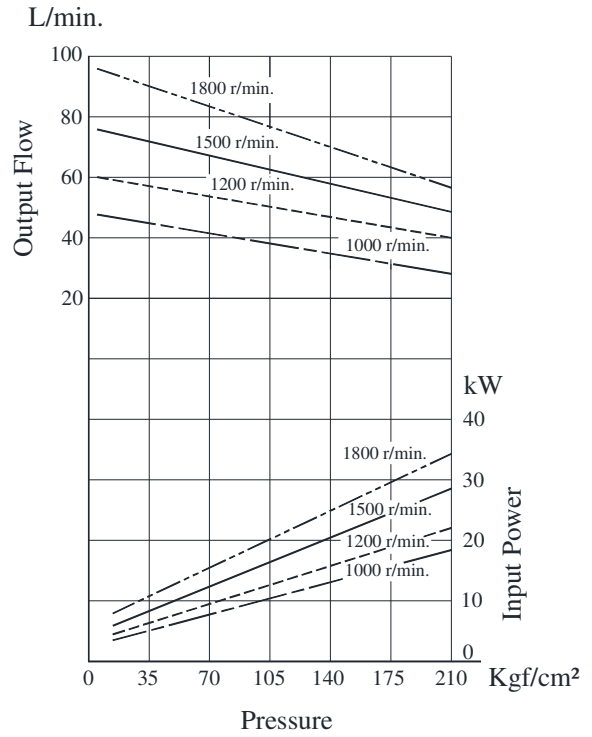

● **PV2R3-60**

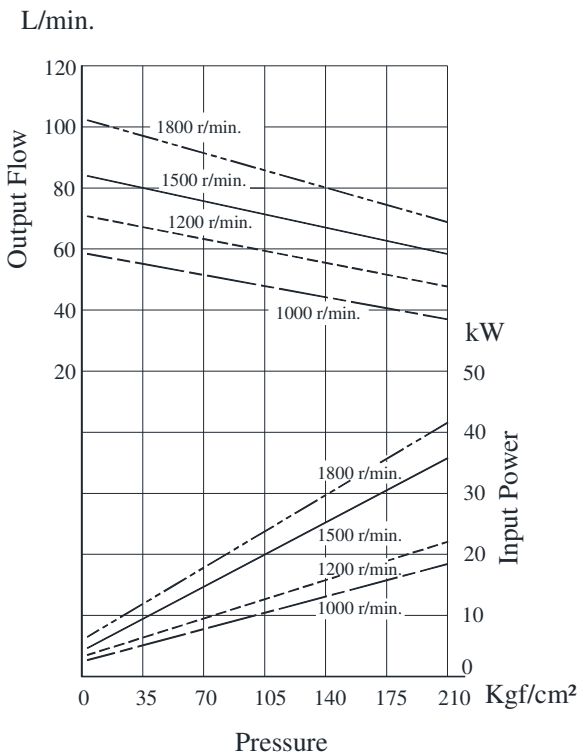

● **PV2R3-66**

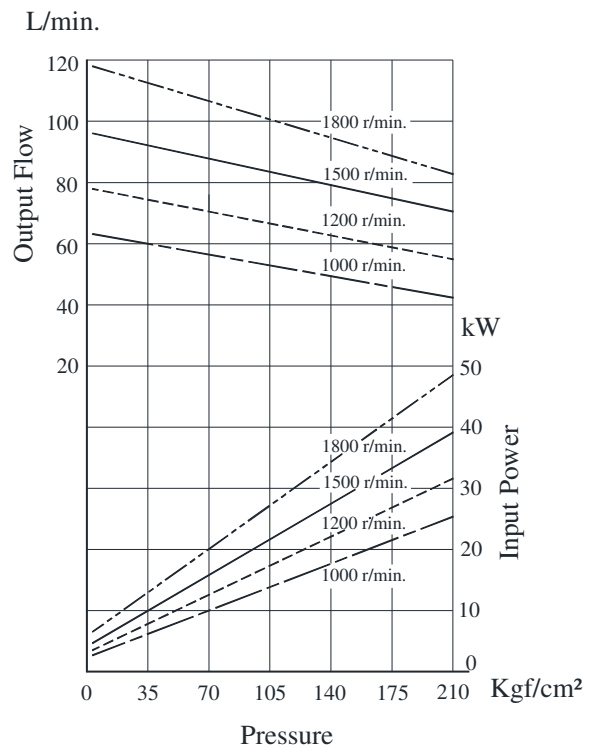

Typical Pump Characteristics Oil Viscosity 20 cSt [ISO VG 32, 50⁰C]

● PV2R3-76

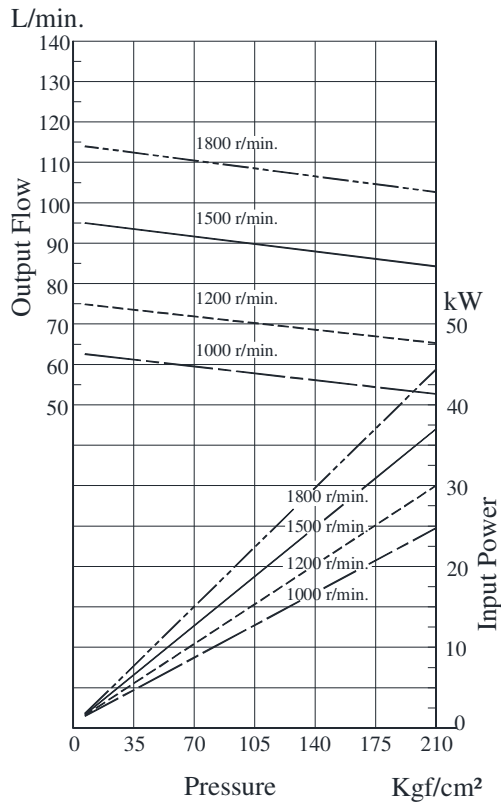

● PV2R3-94

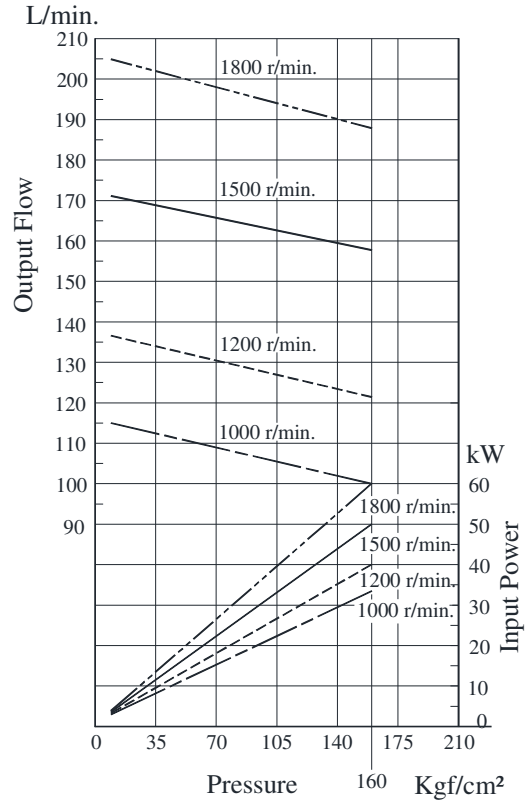

● PV2R3-116

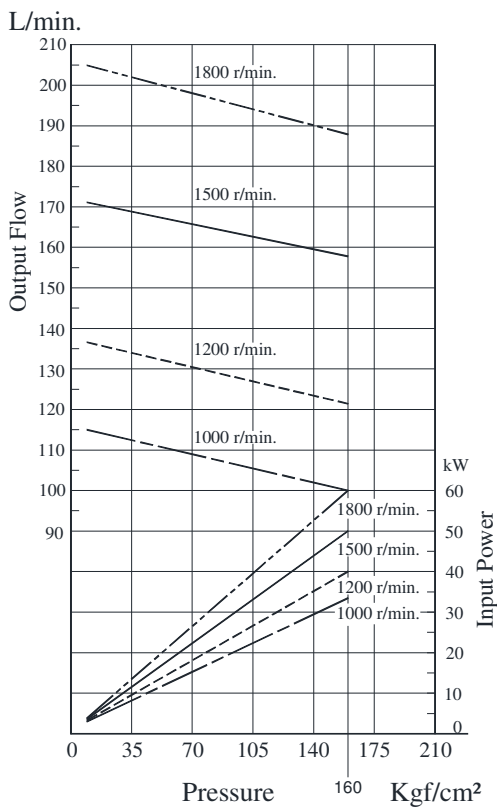

● PV2R4-136

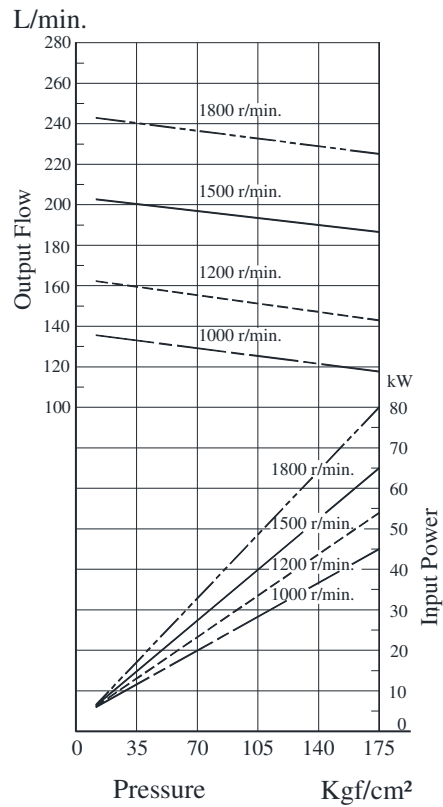

B
PV2R Series
Single Vane Pumps

Typical Pump Characteristics Oil Viscosity 20 cSt [ISO VG 32, 50°C]

● PV2R4-153

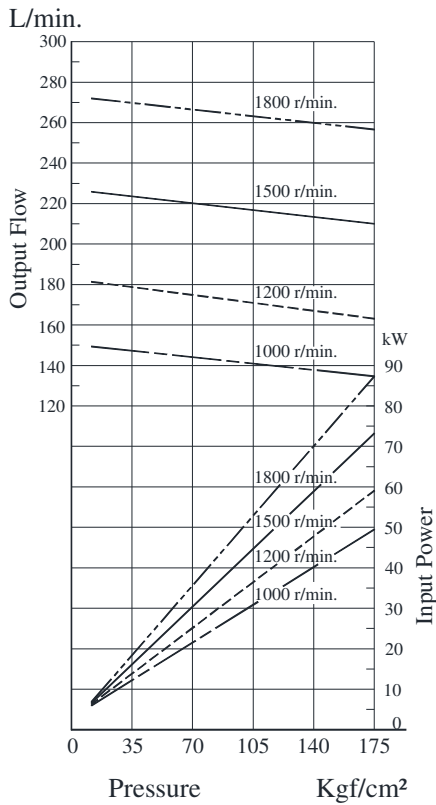

● PV2R4-184

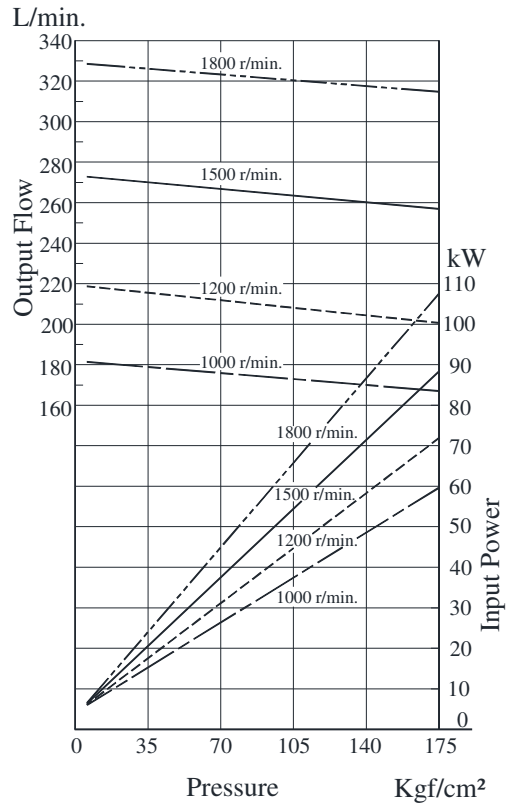

● PV2R4-200

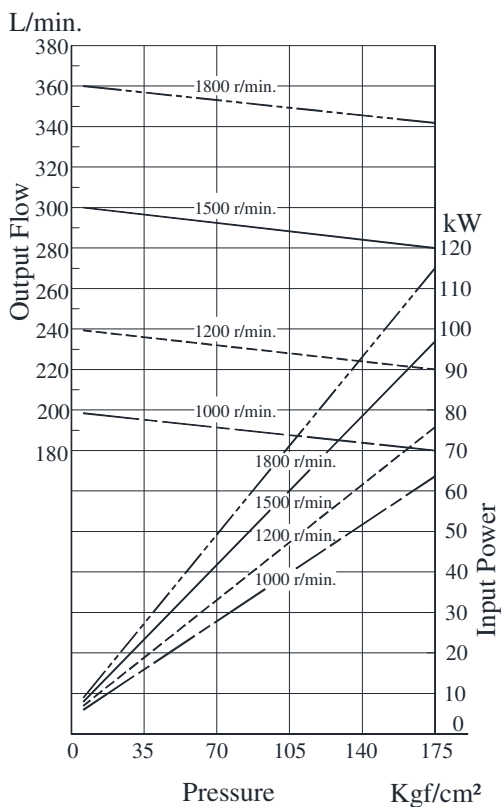

● PV2R4-237

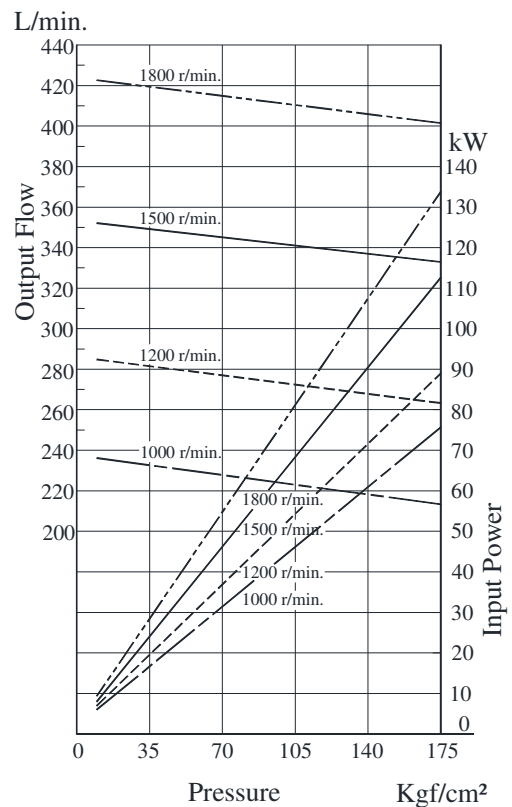

Cartridge Kit Model Number

Model Numbers	Cartridge Kit Numbers	Model Numbers	Cartridge Kit Number
PV2R1-6-※-R※※-43	CPV2R1-6-R-43	PV2R2-26-※-R※※-40	CPV2R2-26-R-40
PV2R1-8-※-R※※-43	CPV2R1-8-R-43	PV2R2-33-※-R※※-40	CPV2R2-33-R-40
PV2R1-10-※-R※※-43	CPV2R1-10-R-43	PV2R2-41-※-R※※-40	CPV2R2-41-R-40
PV2R1-12-※-R※※-43	CPV2R1-12-R-43	PV2R2-47-※-R※※-40	CPV2R2-47-R-40
PV2R1-14-※-R※※-43	CPV2R1-14-R-43	PV2R2-53-※-R※※-40	CPV2R2-53-R-40
PV2R1-17-※-R※※-43	CPV2R1-17-R-43	PV2R2-59-※-R※※-40	CPV2R2-59-R-40
PV2R1-19-※-R※※-43	CPV2R1-19-R-43	PV2R2-65-※-R※※-40	CPV2R2-65-R-40
PV2R1-23-※-R※※-43	CPV2R1-23-R-43	PV2R3-52-※-R※※-31	CPV2R3-52-R-31
PV2R1-25-※-R※※-43	CPV2R1-25-R-43	PV2R3-60-※-R※※-31	CPV2R3-60-R-31
PV2R1-31-※-R※※-43	CPV2R1-31-R-43	PV2R3-66-※-R※※-31	CPV2R3-66-R-31
		PV2R3-76-※-R※※-31	CPV2R3-76-R-31
		PV2R3-94-※-R※※-31	CPV2R3-94-R-31
		PV2R3-116-※-R※※-31	CPV2R3-116-R-31
		PV2R4-136-※-R※※-30	CPV2R4-136-R-30
		PV2R4-153-※-R※※-30	CPV2R4-153-R-30
		PV2R4-184-※-R※※-30	CPV2R4-184-R-30
		PV2R4-200-※-R※※-30	CPV2R1-200-R-30
		PV2R4-237-※-R※※-30	CPV2R4-237-R-30

* For instructions regarding replacing cartridge kit, consult YUKEN INDIA LTD.

Spare Parts List

● **List of Seals**

Sl. No.	Name of Parts	Part Numbers				Qty.
		PV2R1	PV2R2	PV2R3	PV2R4	
1	Oil Seal	ISD 26 42 8	ISD 30 42 8	ISD 35 55 11	ISD 45 68 12	1
2	O-Ring	SO-NB-G80	SO-NB-G105	SO-NB-G135	SO-NB-G145	1
3	O-Ring	-	-	-	SO-NB-P28	1
4	O-Ring	-	-	-	SO-NB-P22A	1
5	O-Ring	SO-NB-G60	SO-NB-G85	SO-NB-G115	SO-NA-G130	1
6	O-Ring	SO-NB-G30	SO-NB-P46	SO-NB-A231	SO-NA-G80	1
7	Back Up Ring	-	-	-	SO-BE-G130	1
8	Back Up Ring	-	-	-	SO-BB-G80	1

● **List of Seal kits**

Pump Model Numbers	Seal Kit Number
PV2R1-※-※-RAA-43	KS-PV2R1-40
PV2R2-※-※-RAA-40	KS-PV2R2-40
PV2R3-※-※-RAA-31	KS-PV2R3-30
PV2R4-※-※-RAA-30	KS-PV2R4-30

PV2R Series Double Vane Pumps

These double pumps consist of two PV2R series single pumps combined in tandem within a single housing and driven by a common shaft. A single suction port and two discharge ports are provided. So that the output flow can be supplied to separate circuits.

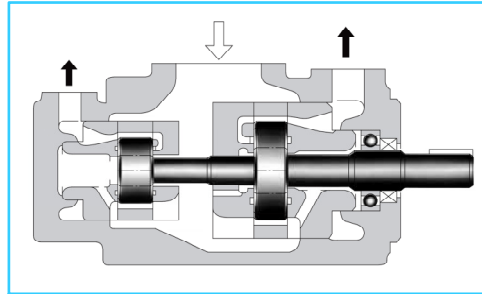
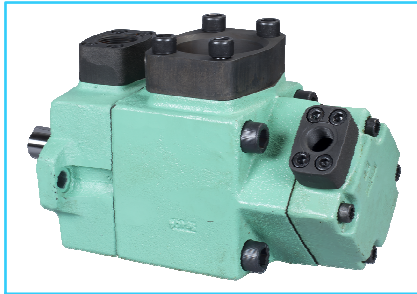

Graphic symbol

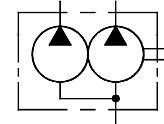

Specifications

Maximum Operating Pressure

Nominal Displacement cm ³ /rev.	Maximum Operating Pressure Kg/cm ²					
	Petroleum Base Oils		Water Containing Fluids			Synthetic Fluids
	Anti-wear Type	R & O Type	Anti-wear Type Water Glycols ^{*3}	Water Glycols	Water in Oil Emulsions	Phosphate Esters
6	210 ^{*1}	160	160	70	70	160
8	210					
10						
12						
14						
17						
19						
23 ^{*2}	210 {160} ^{*2}					
25	210					
31	160					
26	210	140	160	70	70	140
33						
41						
47						
53						
59						
65						
52	210	140	160	70	70	140
60						
66						
76						
94						
116	160					
136	175	140	160	70	70	140
153						
184						
200						
237						

Note: 1) For the relation between model (series) No. and nominal displacement, see the table in next page.

2) As for PV2R12 and PV2R33 series, the sum of the input powers to small volume pump and large volume pump is limited against shaft speed. Refer page - 173

*1 For pressure above 160 Kg/cm², increase the speed over 1450 r/min.

*2 If nominal displacement “23”, with the PV2R14 series, is selected, the maximum operating pressure is limited to 160 Kg/cm².

*3 For the brands of specially Specified & Anti-wear type water Glycol see the ‘hydraulic Fluids’ in page no. 765 of EIC-N-1001.

Model Number Designation

F-	PV2R13	-6	-26	-L	-R	A	A	A	-43
Special Seals	Series Number	Small Volume Pump Nominal Displacement cm ³ /rev.	Large Volume Pump Nominal Displacement cm ³ /rev.	Mounting	Direction of Rotation	Small Volume Pump Discharge Port Position	Large Volume Pump Discharge Port Position	Suction Port Position	Design Number
(As viewed from Shaft End)									
F: Special Seals for Phosphate Ester type Fluids (Omit if not required)	PV2R12	6, 8	26, 33	L: Foot Mtg.	R: *1 Clock wise (Normal)	E: Left 45° Upwards (Normal)	A: Upward (Normal)	A: Upward (Normal)	40 *2
		10, 12	41, 47						43
	14, 17	53, 59	41						
	19, 23	65	31						
	25, 31	76, 94	33						
	116	116	31						
	116	116	31						
PV2R13	6, 8	76, 94	F: Flange Mtg.	E: Left 45° Upwards (Normal)	A: Upward (Normal)	A: Upward (Normal)	A: Upward (Normal)	31	
PV2R23	10, 12	52, 60						33	
	14, 17	66, 76						31	
PV2R33	19, 23	94, 116						31	
	25, 31	136, 153						31	
PV2R14	26, 23	184, 200						31	
	41, 47	237						31	
PV2R24	52, 60	136, 153	31						
	66, 76	184, 200	31						
PV2R34	94, 116	136, 153	31						
	116	184, 200	31						

B

PV2R Series
Double Vane Pumps

*1 Available to supply pump with anti-clockwise rotation. Consult Yuken for details.

* For instructions regarding changing the port positions, consult YUKEN INDIA LTD.

*2 Please consult YUKEN, some configurations may manufactured in india (40D).

Relation between Model No. and Nominal Displacement.

		Nominal Displacement, Large Volume pump			
		26, 33, 41, 47 53, 59, 65	52, 60 66	76, 94 116	136, 153, 184 200, 237
Nominal Displacement Small Volume pump	6	PV2R12	—	PV2R13	PV2R14
	8				
	10				
	12				
	14				
	17				
	19				
23					
25	—	PV2R23	—	—	
31					
26					
33					
41					
47					
53					
59					
65					
52	—	—	—	PV2R34	
60					
66					
76					
94					
116					
116					

Sum of Input Power to Small Volume Pump and Large Volume Pump

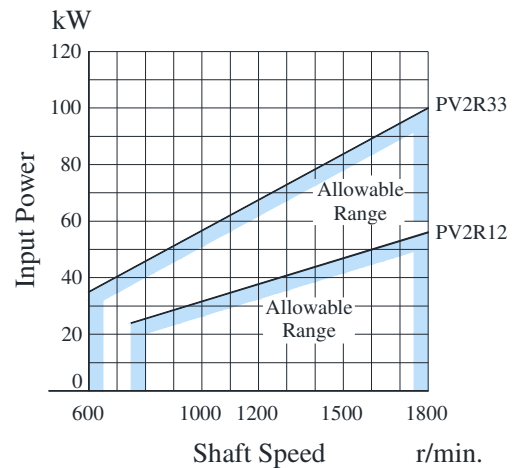

● **Shaft Speed Range**

Model Number	Shaft Speed Range r/min.			
	Petroleum Base Oils		Water containing Fluids Phosphate Esters	
	Max.	Min.	Max.	Min.
PV2R12	1800	750 ^{*3}	1200	750 ^{*3}
PV2R13	1800 ^{*2}	750 ^{*3}	1200	750 ^{*3}
PV2R23	1800 ^{*2}	600 ^{*3}	1200	600 ^{*3}
PV2R33	1800 ^{*2} (1500) ^{*1}	600	1200	600
PV2R14	1800 ^{*2}	750 ^{*3}	1200	750 ^{*3}
PV2R24	1800 ^{*2}	600 ^{*3}	1200	600 ^{*3}
PV2R34	1800 ^{*2}	600	1200	600

*1 With PV2R33-166-166, the maximum speed is limited to 1500 r/min.

*2 With the models (nominal displacements) listed below, the minimum suction pressures are limited in accordance with speeds.

[With other models, the minimum suction pressure is - 0.2 Kg/cm² irrespective of speed.]

*3 For starting at low speed, the maximum viscosity is limited. For details, see the item of “Hydraulic Fluids” on page 116.

Model Number	Min. Suction Pressure Kg/cm ²	
	Less than 1700 r/min.	1700 ~ 1800 r/min.
PV2R13-※-116	-0.2	0
PV2R23-※-116		
PV2R23-※-76	-0.2	-0.07
PV2R23-※-94		
PV2R33-※-76		
PV2R33-※-94-※-	-0.2	0
PV2R33-※-116-※-		
PV2R33-※-94		
PV2R33-※-116		
PV2R14-※-237	-0.2	-0.13
PV2R24-※-237		
PV2R34-※-237		
PV2R34-※-116-※-	-0.2	0

● **Mass**

Model Number Mounting	Approx. Mass Kg.						
	PV2R12	PV2R13	PV2R23	PV2R33	PV2R14	PV2R24	PV2R34
Flange Mtg.	25	45.6	51	84	75	78	98
Foot Mtg.	29.3	55.6	61	94	100	103	123

● **Output Flow & Input Power**

The pump characteristics are the same as for PV2R series single pumps. See the corresponding page.

Model Numbers	Output Flow & input Power	
	Small Volume Pump	Large Volume Pump
PV2R12	Same as single pump "PV2R1", refer page 154, 155 & 156.	Same as single pump "PV2R2", refer page 156, 157 & 158 However, as for displacement of "26" & "33" ref. page 173.
PV2R13	Same as single pump "PV2R1", refer page 154, 155 & 156.	Same as single pump "PV2R3", refer page 158 & 159
PV2R23	Same as single pump "PV2R2", refer page 156, 157 & 158.	Same as single pump "PV2R3", refer page 158 & 59 However, as for displacement of "52", "60" & "66" ref. page 173 & 174.
PV2R33	Same as single pump "PV2R3", refer page 156, 157 & 158	Same as single pump "PV2R3", refer page 156, 157 & 158
PV2R14	Same as single pump "PV2R1", refer page 154, 155 & 156.	Same as single pump "PV2R4", refer page 159 & 160
PV2R24	Same as single pump "PV2R2", refer page 156, 157 & 158 However, as for displacement of "26" & "33" ref. page 173.	
PV2R34	Same as single pump "PV2R3", refer page 158 & 159 However, as for displacement of "52", "60" & "66" ref. page 173 & 174.	

■ **Pipe Flange Kits**

Pipe flange kits are available. When ordering, specify kits from the table below.

Pump Model Numbers	Name of Port	Pipe Flange Kit Numbers	Pump Model Numbers	Name of Port	Pipe Flange Kit Numbers
		Threaded connection			Threaded connection
PV2R12	Suction	F5-16-A-1080	PV2R14	Suction	---
	Large Discharge	F5-06-A-1080		Large Discharge	F5-12-A-1080
	Small Discharge	F5-04-A-1080		Small Discharge	F5-04-A-1080
PV2R13	Suction	---	PV2R24	Suction	---
	Large Discharge	F5-10-A-1080		Large Discharge	F5-12-A-1080
	Small Discharge	F5-04-A-1080		Small Discharge	F5-06-A-1080
PV2R23	Suction	---	PV2R34	Suction	---
	Large Discharge	F5-10-A-1080		Large Discharge	F5-12-A-1080
	Small Discharge	F5-06-A-1080		Small Discharge	F5-10-A-1080
PV2R33	Suction	---			
	Large Discharge	F5-10-A-1080			
	Small Discharge	F5-10-A-1080			

Note: Special seals (Viton seals) are required when phosphate ester type fluids are used.

- Detail of the pipe flange kit is described EIC-L-1001.

PV2R12-※-※-F-R※AA-40

● **Flange Mounting**

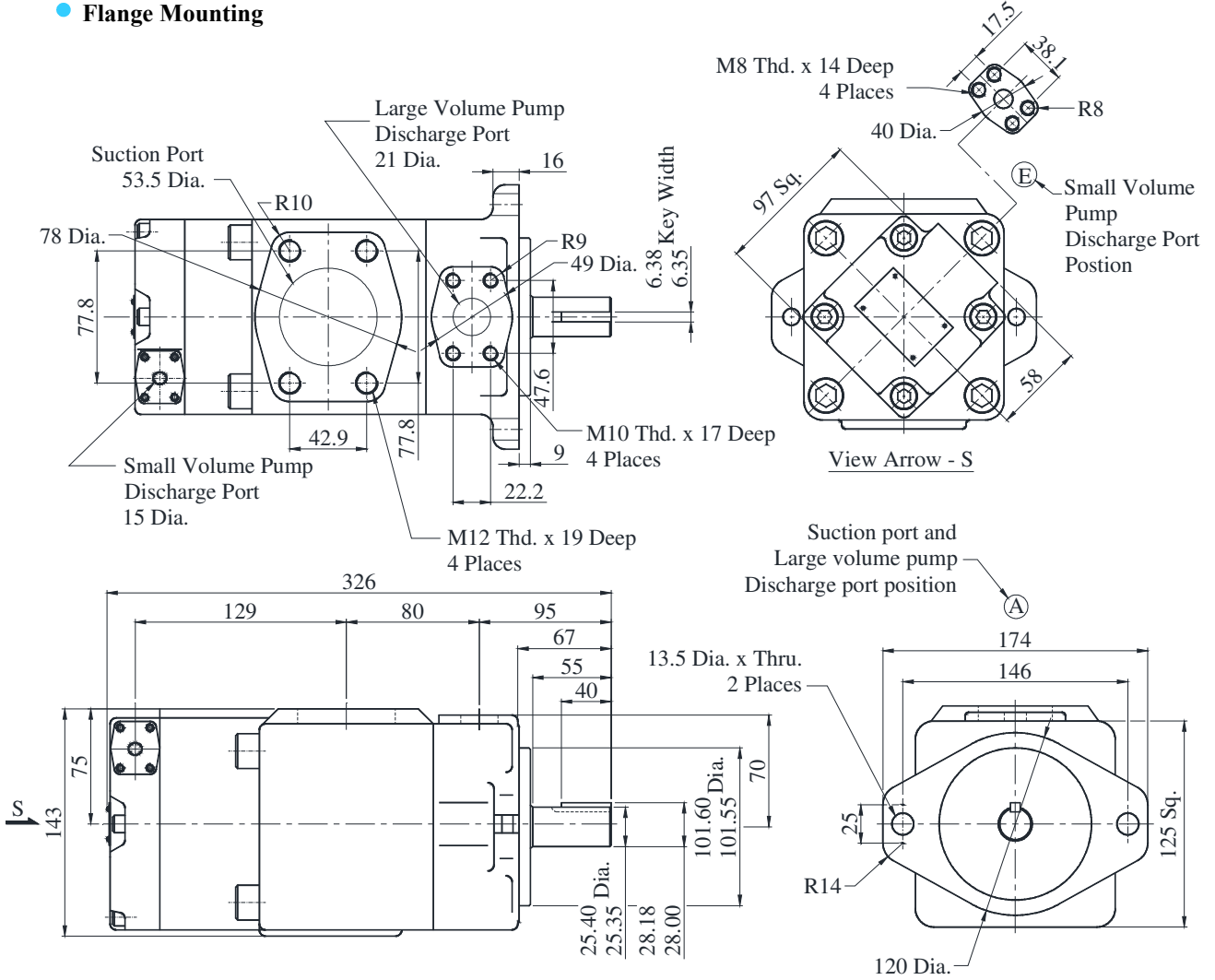

DIMENSIONS IN MILLIMETRES

PV2R12-※-※-L-R※AA-40

● **Foot Mounting**

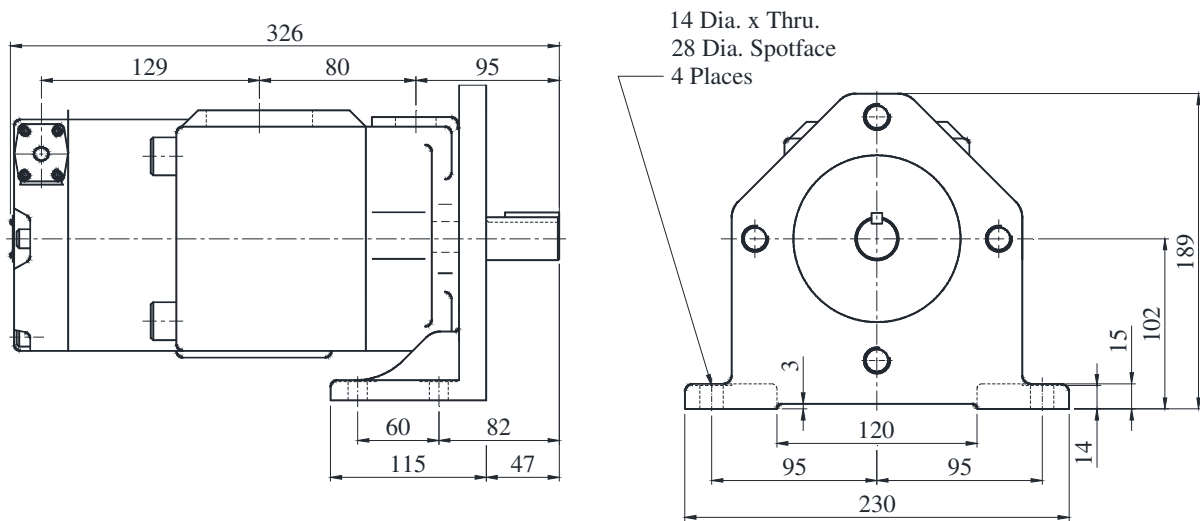

● For other Dimensions, refer to “Flange Mtg.”

PV2R13-※-※-F-R※AA-43

● **Flange Mounting**

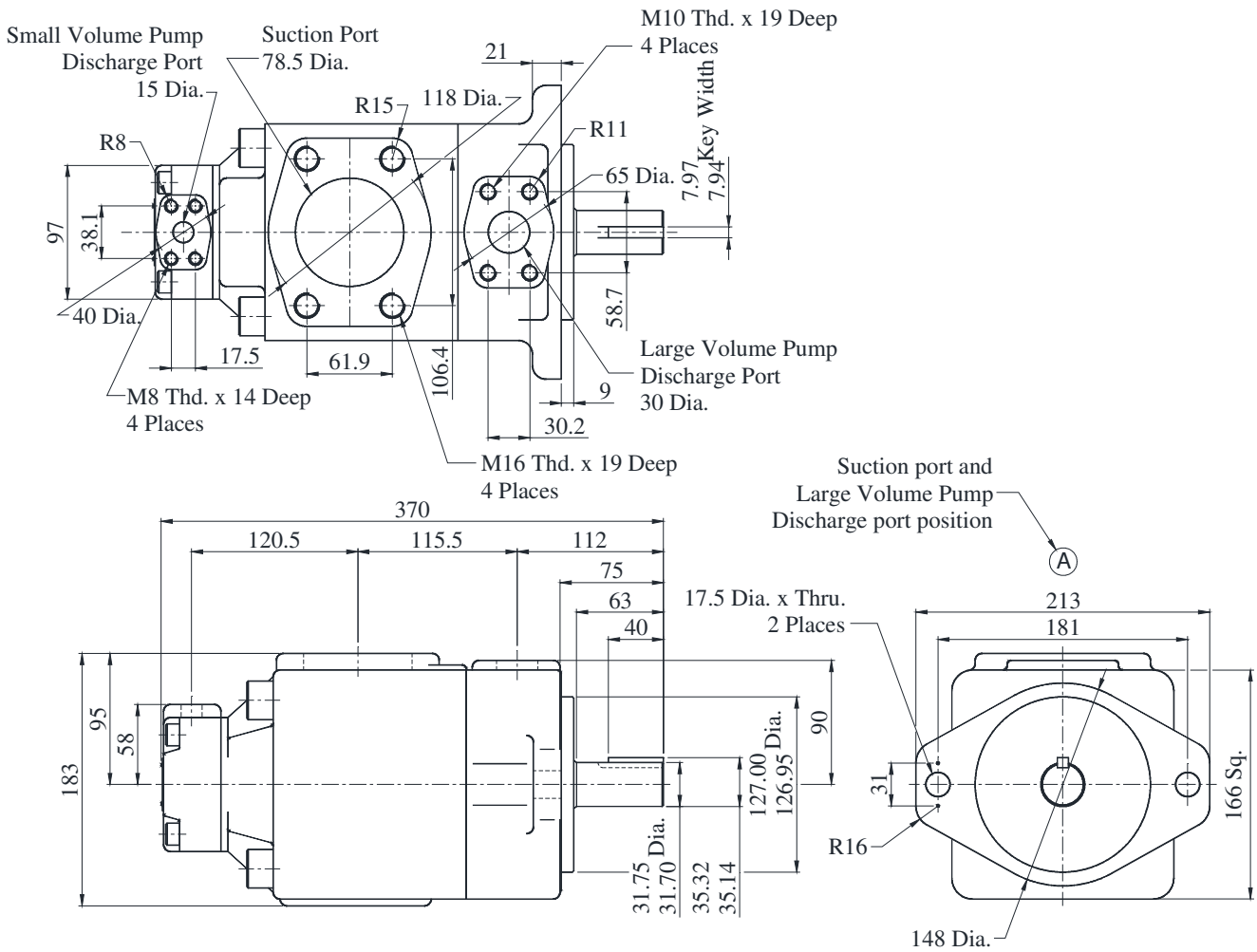

DIMENSIONS IN MILLIMETRES

PV2R13-※-※-L-R※AA-43

● **Foot Mounting**

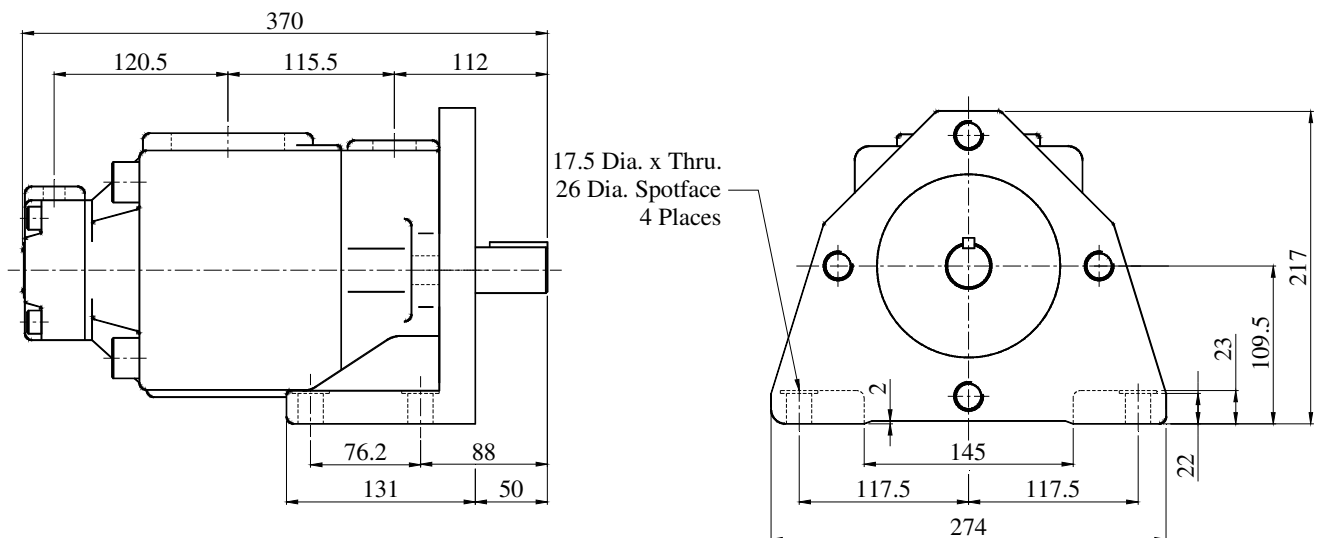

● For other Dimensions, refer to “Flange Mtg.”

B
PV2R Series
Double Vane Pumps

PV2R23-※-※-F-R※AA-41

● Flange Mounting

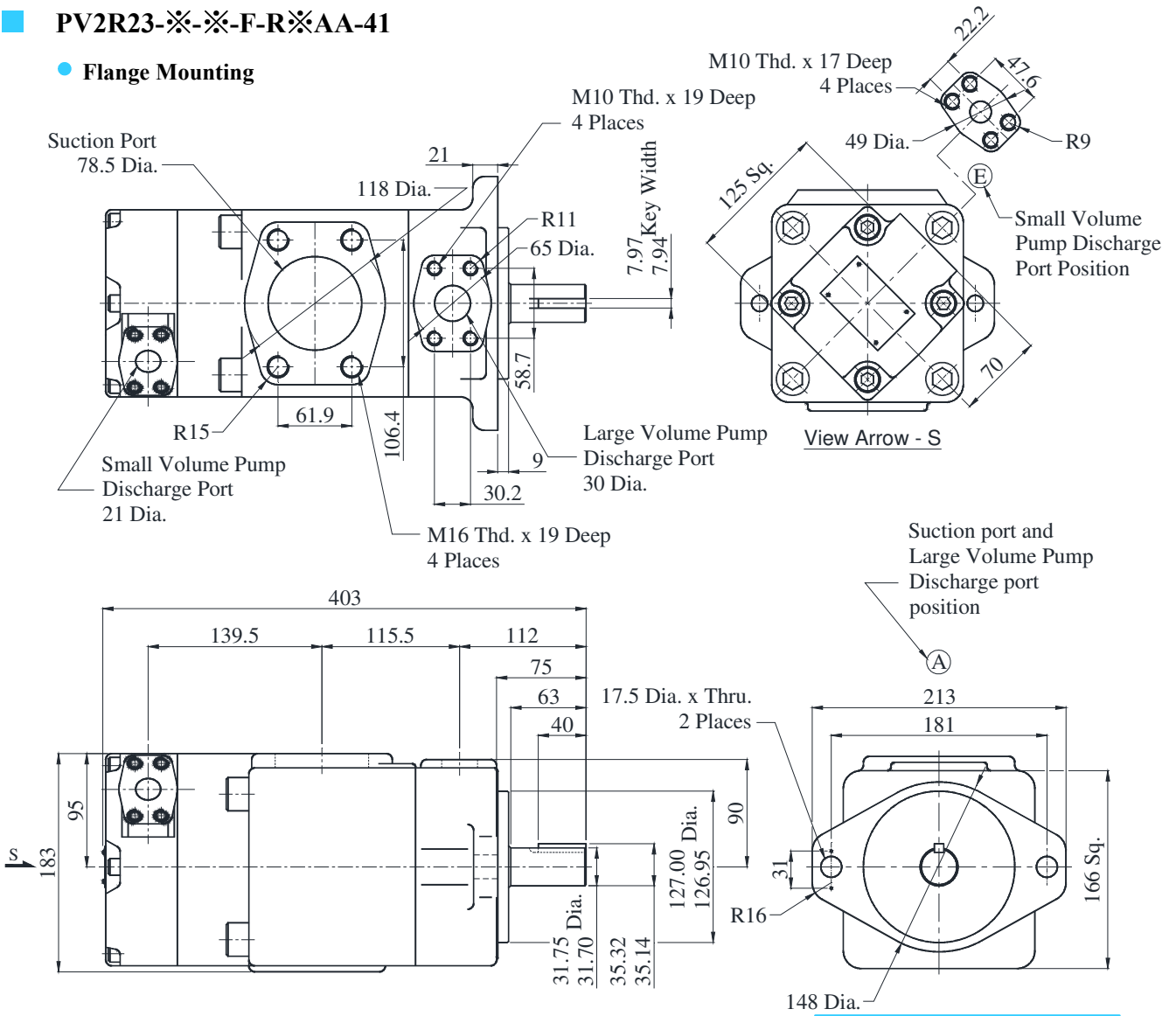

DIMENSIONS IN MILLIMETRES

PV2R23-※-※-L-R※AA-41

● Foot Mounting

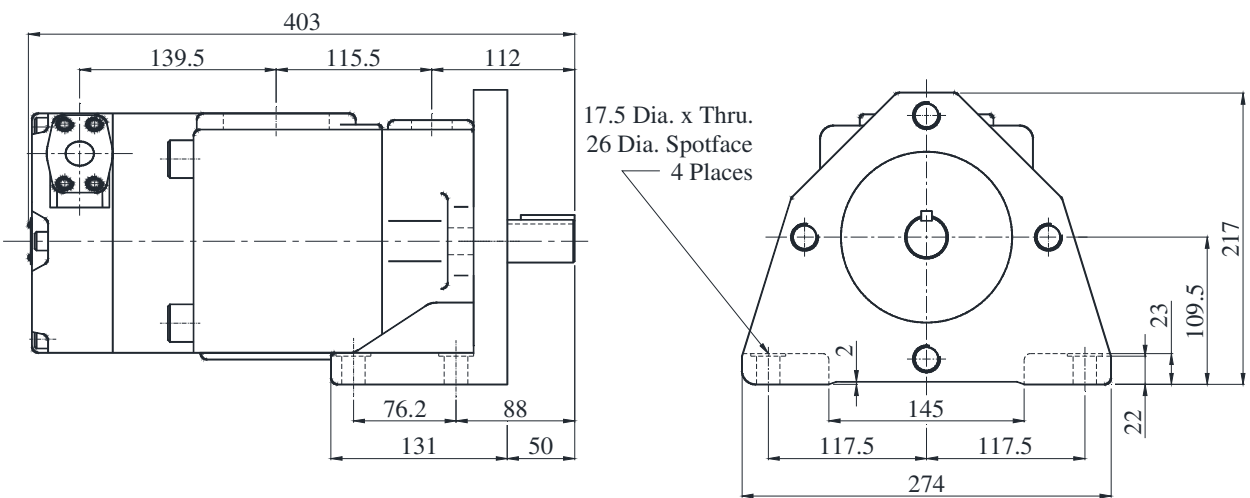

● For other Dimensions, refer to “Flange Mtg.”

PV2R33-※-※-F-R※AA-31

● **Flange Mounting**

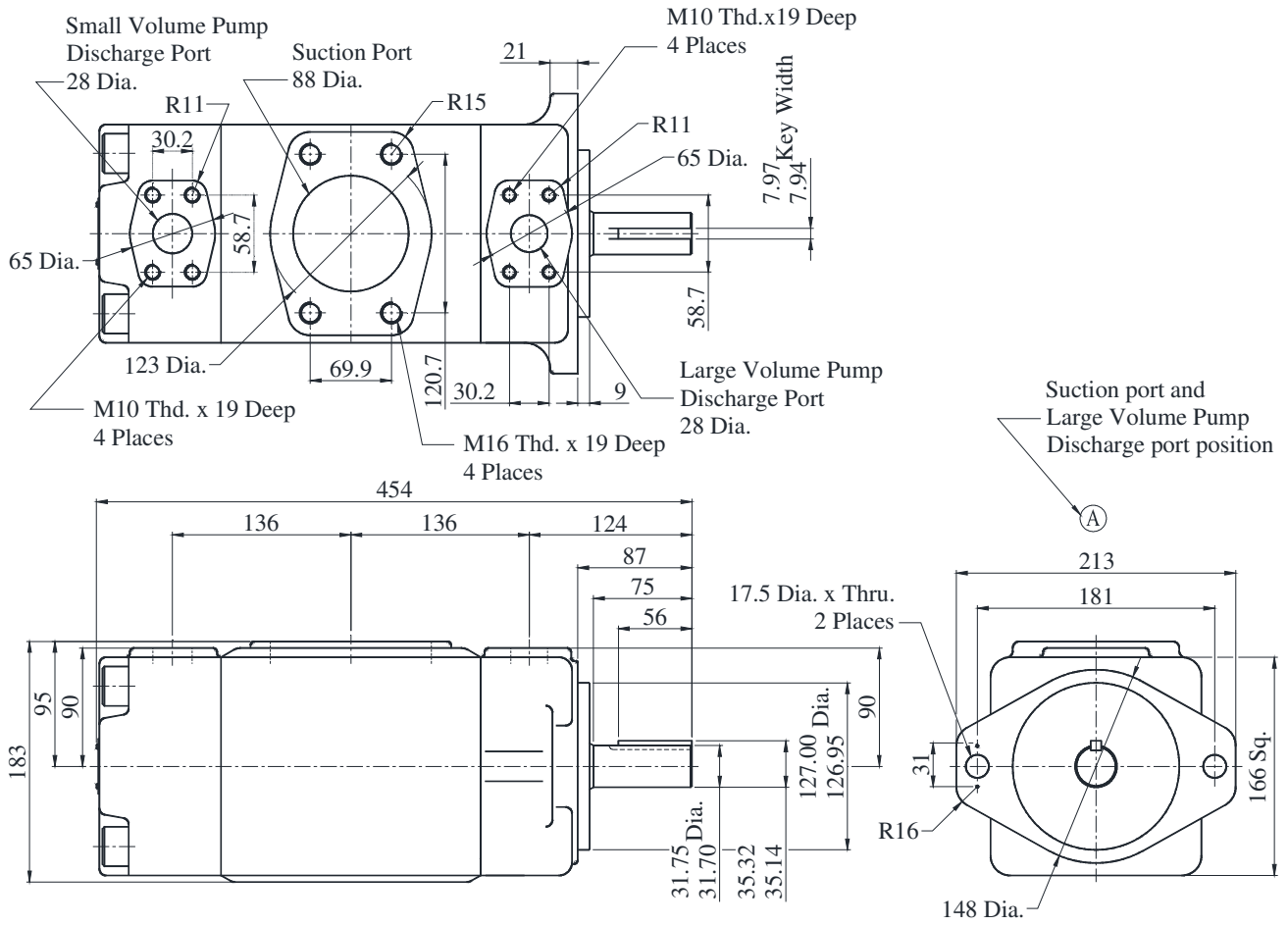

DIMENSIONS IN MILLIMETRES

PV2R33-※-※-L-R※AA-31

● **Foot Mounting**

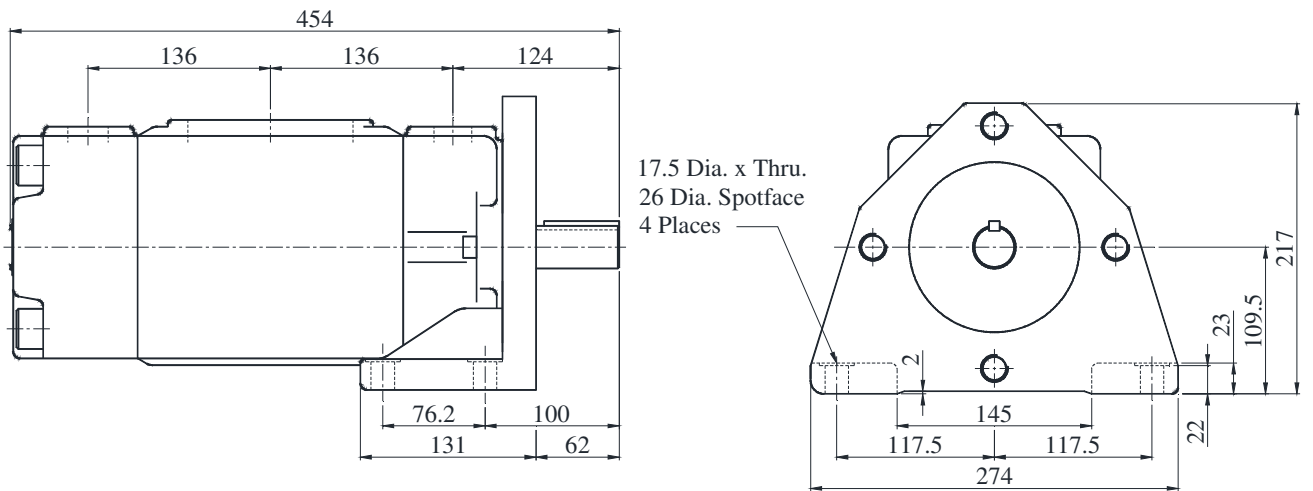

● For other Dimensions, refer to "Flange Mtg."

PV2R14-※-※-F-R※AA-32

● **Flange Mounting**

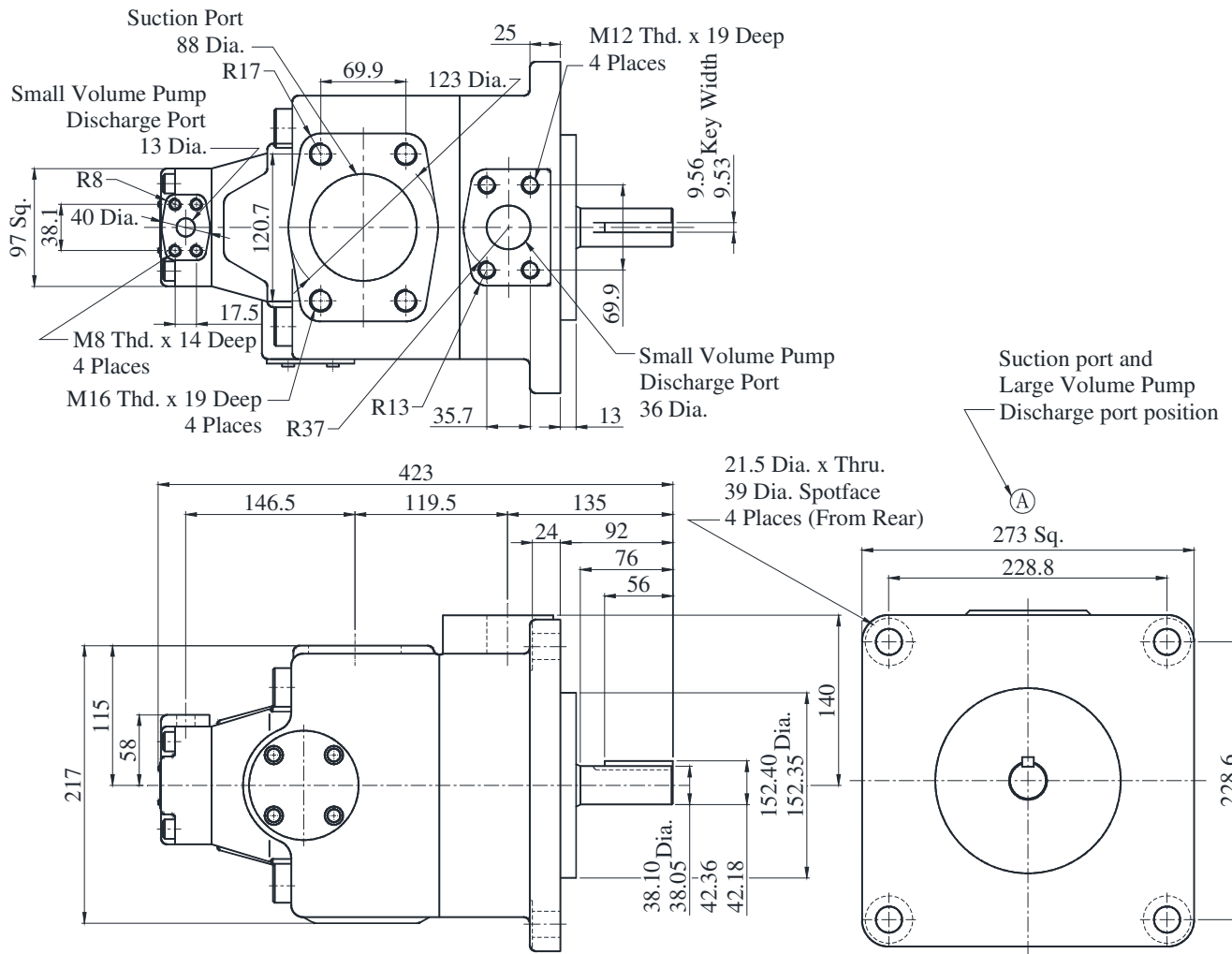

DIMENSIONS IN MILLIMETRES

PV2R14-※-※-L-R※AA-32

● **Foot Mounting**

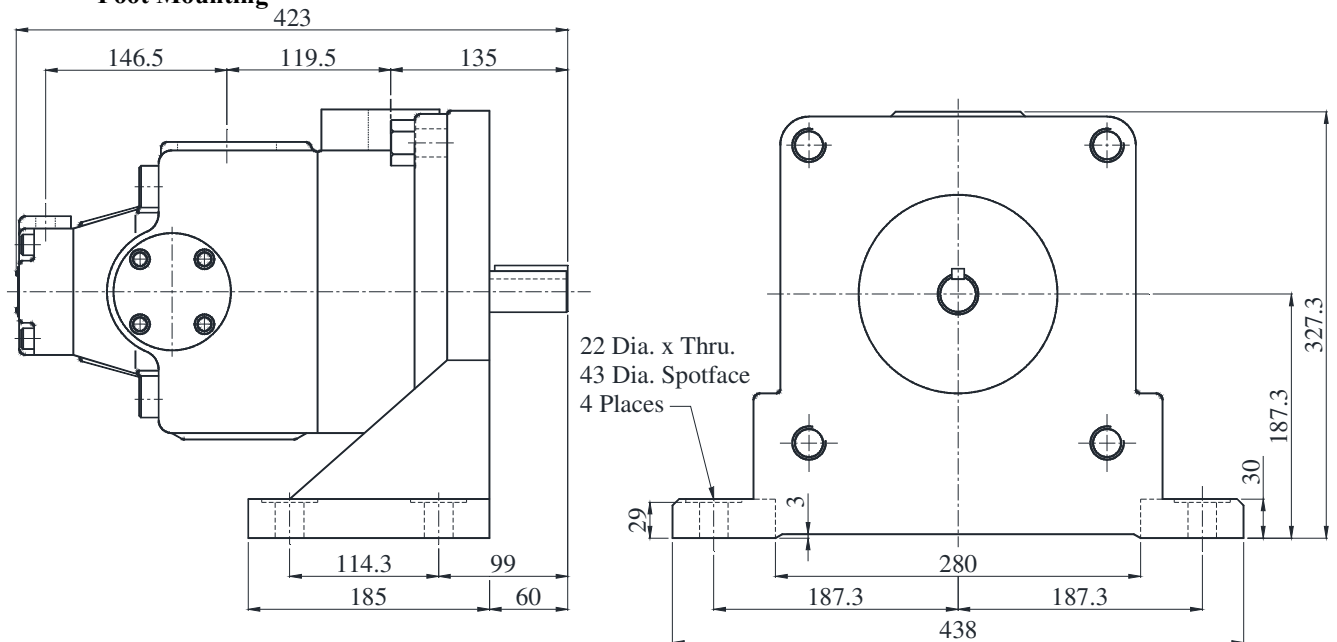

● For other Dimensions, refer to “Flange Mtg.”

PV2R24-※-※-F-R※AA-31

● **Flange Mounting**

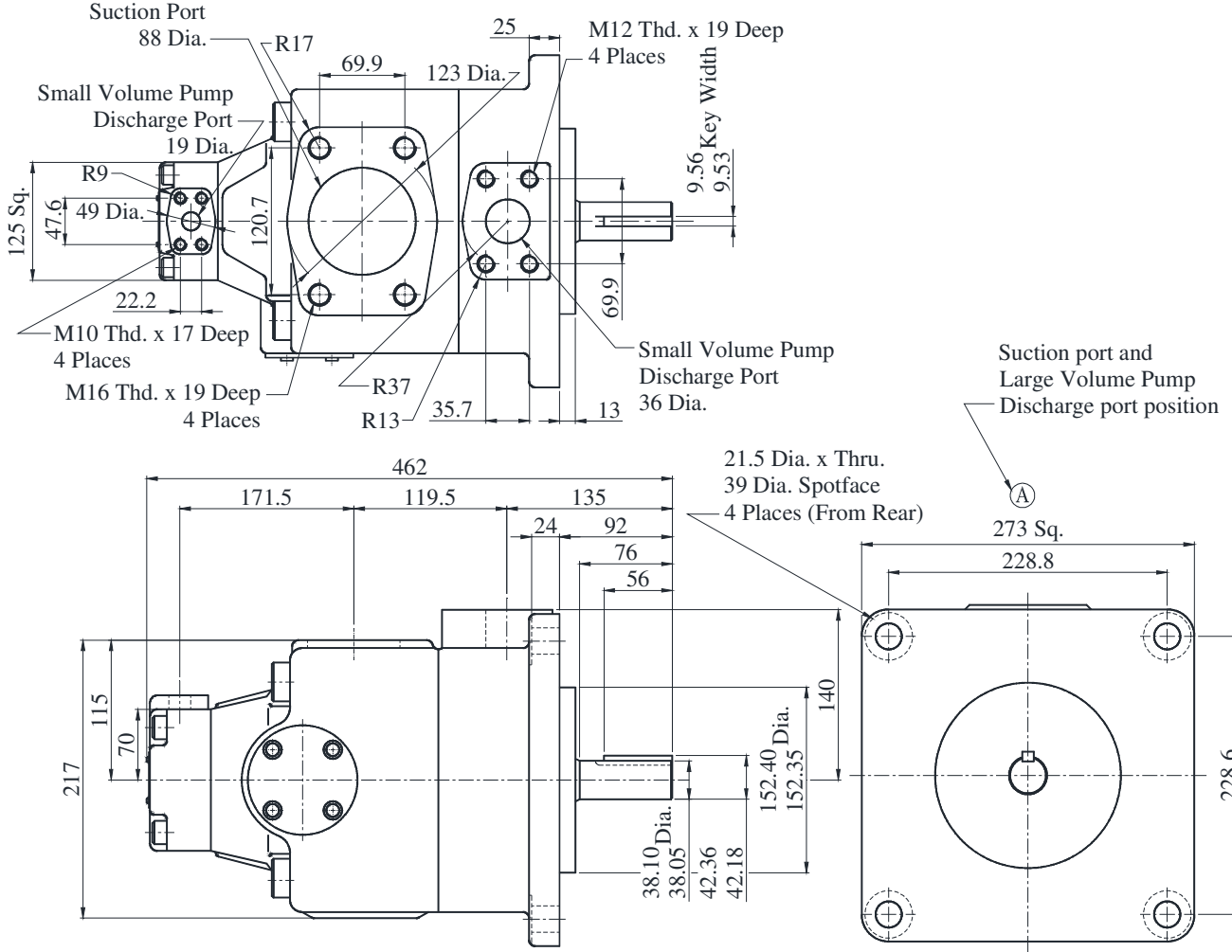

DIMENSIONS IN MILLIMETRES

PV2R24-※-※-L-R※AA-31

● **Foot Mounting**

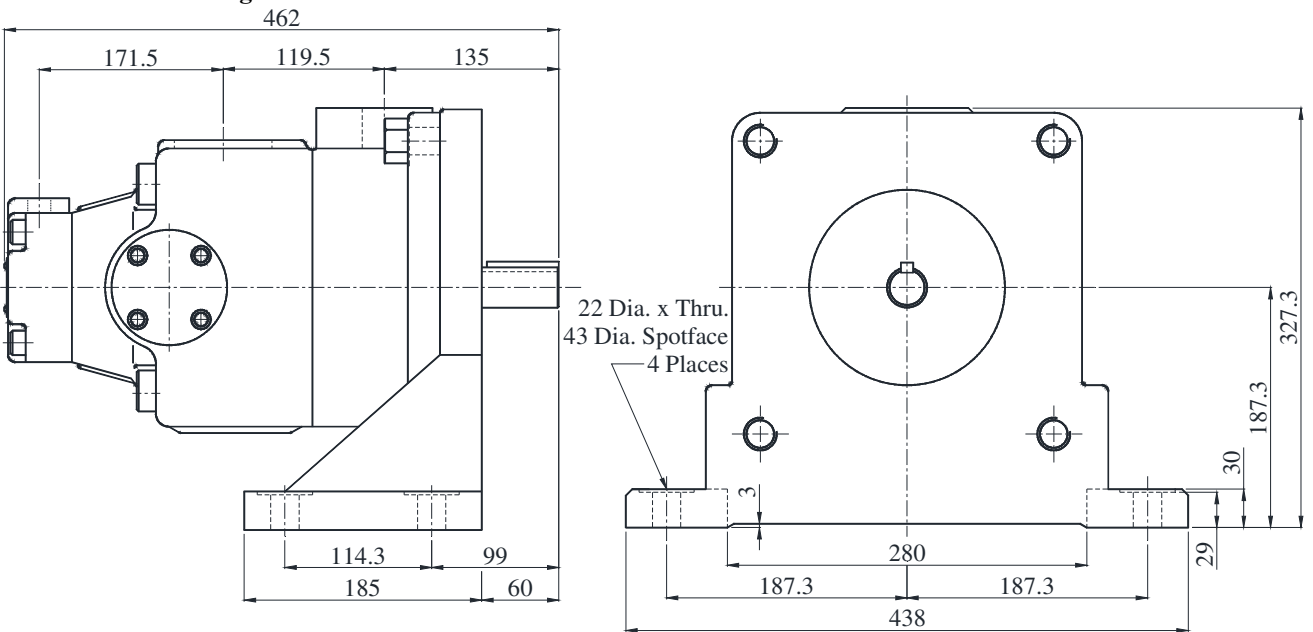

● For other Dimensions, refer to "Flange Mtg."

PV2R34-※-※-F-R※AA-31

● **Flange Mounting**

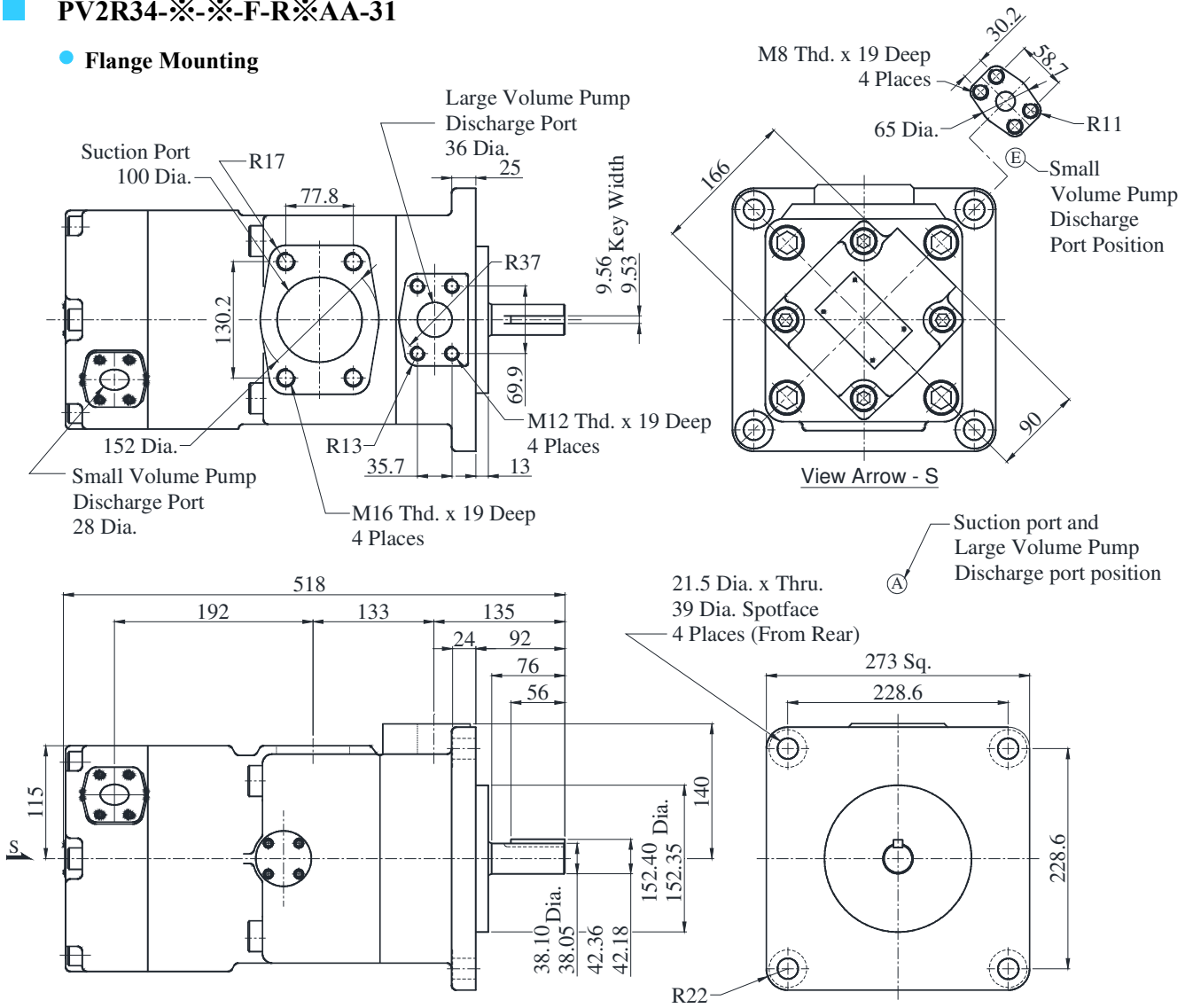

DIMENSIONS IN MILLIMETRES

PV2R34-※-※-L-R※AA-31

● **Foot Mounting**

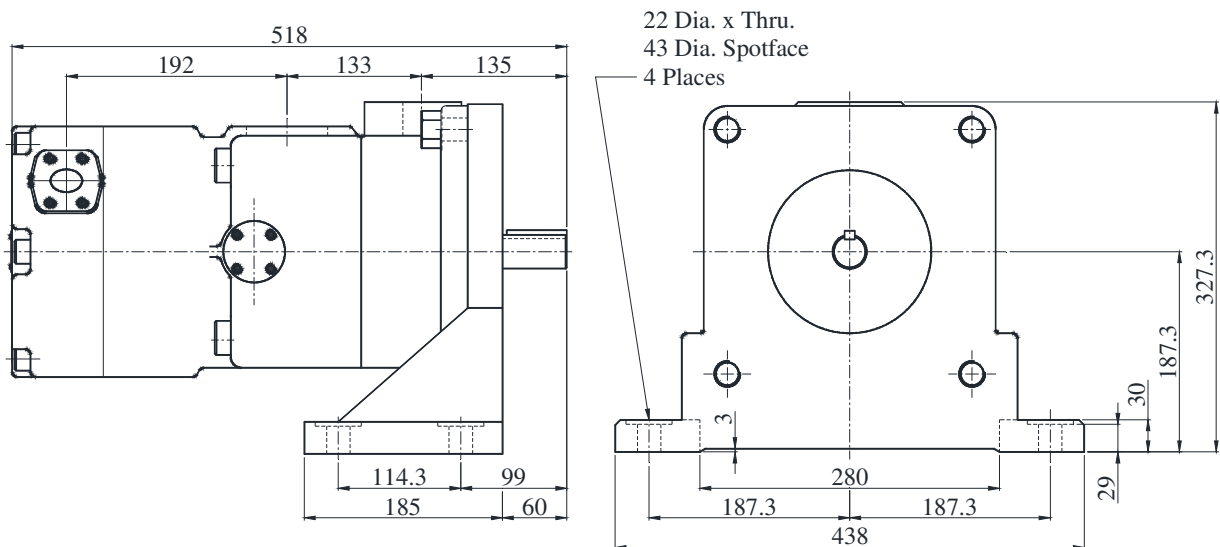

● For other Dimensions, refer to "Flange Mtg."

Typical Pump Characteristics Oil Viscosity 20 cSt [ISO VG 32, 50°C]

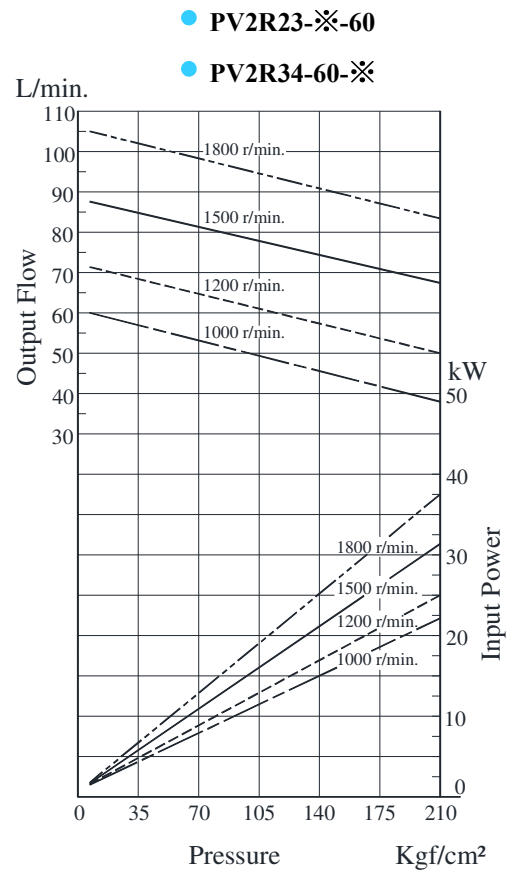
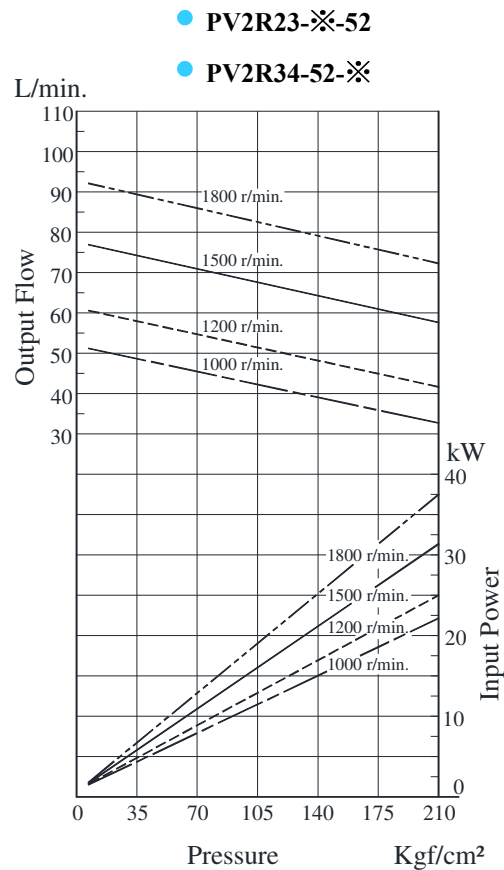
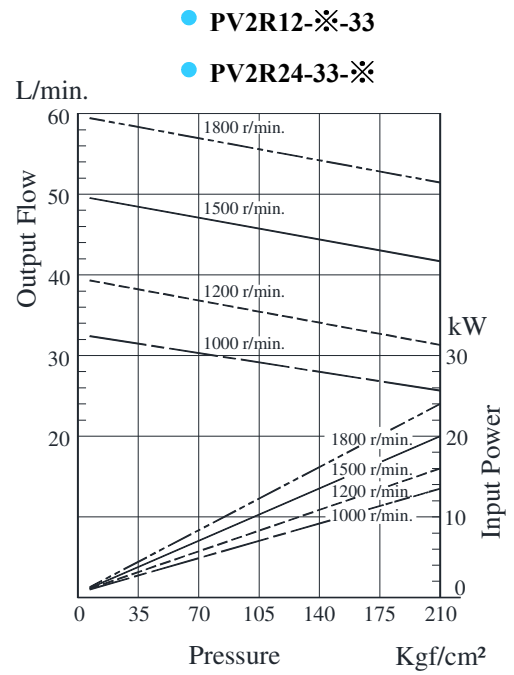
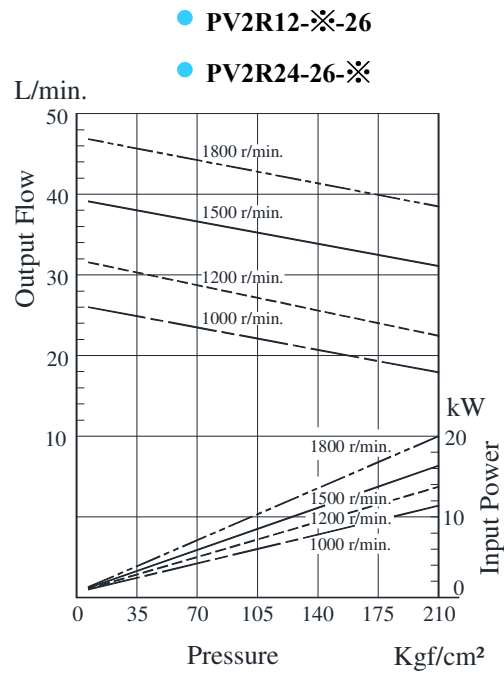

B
PV2R Series
Double Vane Pumps

Typical Pump Characteristics Oil Viscosity 20 cSt [ISO VG 32, 50°C]

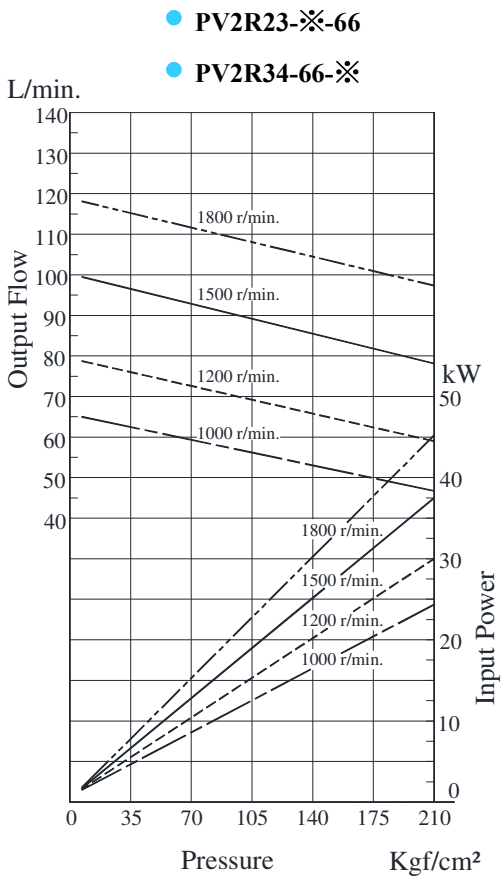

Cartridge Kit Model Number

Model Numbers	Cartridge Kit Numbers	
	Small Volume Pumps	Large Volume Pumps
PV2R12-6-* ※ -REAA-40	CPV2R13-6-L-40	CPV2R2-* ※ -R-40
PV2R12-8-* ※ -REAA-40	CPV2R13-8-L-40	
PV2R12-10-* ※ -REAA-40	CPV2R13-10-L-40	
PV2R12-12-* ※ -REAA-40	CPV2R13-12-L-40	
PV2R12-14-* ※ -REAA-40	CPV2R13-14-L-40	
PV2R12-17-* ※ -REAA-40	CPV2R13-17-L-40	
PV2R12-19-* ※ -REAA-40	CPV2R13-19-L-40	
PV2R12-23-* ※ -REAA-40	CPV2R13-23-L-40	
PV2R12-25-* ※ -REAA-40	CPV2R13-25-L-40	
PV2R12-31-* ※ -REAA-40	CPV2R13-31-L-40	
PV2R13-6-* ※ -RAAA-43	CPV2R13-6-L-43	CPV2R3-* ※ -R-31
PV2R13-8-* ※ -RAAA-43	CPV2R13-8-L-43	
PV2R13-10-* ※ -RAAA-43	CPV2R13-10-L-43	
PV2R13-12-* ※ -RAAA-43	CPV2R13-12-L-43	
PV2R13-14-* ※ -RAAA-43	CPV2R13-14-L-43	
PV2R13-17-* ※ -RAAA-43	CPV2R13-17-L-43	
PV2R13-19-* ※ -RAAA-43	CPV2R13-19-L-43	
PV2R13-23-* ※ -RAAA-43	CPV2R13-23-L-43	
PV2R13-25-* ※ -RAAA-43	CPV2R13-25-L-43	
PV2R13-31-* ※ -RAAA-43	CPV2R13-31-L-43	
PV2R23-41-* ※ -REAA-41	CPV2R23-41-L-41	CPV2R3-* ※ -R-31
PV2R23-47-* ※ -REAA-41	CPV2R23-47-L-41	
PV2R23-53-* ※ -REAA-41	CPV2R23-53-L-41	
PV2R23-59-* ※ -REAA-41	CPV2R23-59-L-41	
PV2R23-65-* ※ -REAA-41	CPV2R23-65-L-41	
PV2R33-76-* ※ -RAAA-31	CPV2R33-76-L-31	CPV2R33-* ※ -R-31
PV2R33-94-* ※ -RAAA-31	CPV2R33-94-L-31	
PV2R33-116-* ※ -RAAA-31	CPV2R33-116-L-31	

* For instructions regarding replacing cartridge kit, consult YUKEN INDIA LTD.

Spare Parts List

● **List of Seals**

Sl. No.	Name of Parts	Part Numbers				Qty.
		PV2R12	PV2R13	PV2R23	PV2R33	
1	Oil Seal	ISD 30 42 8	ISD 35 55 11	ISD 35 55 11	ISD 35 55 11	1
2	O-Ring	SO-NB-G105	SO-NB-G135	SO-NB-G135	SO-NB-G135	1
3	O-Ring	SO-NB-G80	SO-NB-G80	SO-NB-G105	SO-NB-G135	1
4	O-Ring	SO-NB-G85	SO-NB-G115	SO-NB-G115	SO-NB-G115	1
5	O-Ring	SO-NB-P46	SO-NB-A231	SO-NB-A231	SO-NA-A231	1
6	O-Ring	SO-NB-G60	SO-NB-G60	SO-NB-G85	SO-NB-G115	1
7	O-Ring	SO-NB-G30	SO-NB-G30	SO-NB-P46	SO-NB-A231	1

Cartridge Kit Model Number

Pump Model Numbers	Cartridge Kit Number	
	Small Volume Pump	Large Volume Pump
PV2R14-6-※-※-RAAA-33	CPV2R13-6-L-43	CPV2R2-※-R-41
PV2R14-8-※-※-RAAA-33	CPV2R13-8-L-43	
PV2R14-10-※-※-RAAA-33	CPV2R13-10-L-43	
PV2R14-12-※-※-RAAA-33	CPV2R13-12-L-43	
PV2R14-14-※-※-RAAA-32	CPV2R13-14-L-43	
PV2R14-17-※-※-RAAA-33	CPV2R13-17-L-43	
PV2R14-19-※-※-RAAA-33	CPV2R13-19-L-43	
PV2R14-23-※-※-RAAA-33	CPV2R13-23-L-43	
PV2R24-26-※-※-RAAA-31	CPV2R23-26-L-41	CPV2R4-※-R-30
PV2R24-33-※-※-RAAA-31	CPV2R23-33-L-41	
PV2R24-41-※-※-RAAA-31	CPV2R23-41-L-41	
PV2R24-47-※-※-RAAA-31	CPV2R23-47-L-41	
PV2R34-52-※-※-REAA-31	CPV2R33-52-L-31	CPV2R34-※-R-30
PV2R34-60-※-※-REAA-31	CPV2R33-60-L-31	
PV2R34-66-※-※-REAA-31	CPV2R33-66-L-31	
PV2R34-76-※-※-REAA-31	CPV2R33-76-L-31	
PV2R34-94-※-※-REAA-31	CPV2R33-94-L-31	

* For instructions regarding replacing cartridge kit, consult YUKEN INDIA LTD.

Spare Parts List

List of Seals

Sl. No.	Name of Parts	Part Numbers			Qty.
		PV2R14	PV2R24	PV2R34	
1	Oil Seal	ISD 45 68 12	ISD 45 68 12	ISD 45 68 12	1
2	O-Ring	SO-NB-G145	SO-NB-G145	SO-NB-G145	1
3	O-Ring	SO-NB-G80	SO-NB-G105	SO-NB-G135	1
4	O-Ring	SO-NB-P28	SO-NB-P28	SO-NB-P28	1
5	O-Ring	SO-NB-P22A	SO-NB-P22A	SO-NB-P22A	1
6	O-Ring	SO-NA-G130	SO-NA-G130	SO-NA-G130	1
7	O-Ring	SO-NA-G80	SO-NA-G80	SO-NA-G80	1
8	Backup-Ring	SO-BE-G130	SO-BE-G130	SO-BE-G130	1
9	Backup-Ring	SO-BB-G80	SO-BB-G80	SO-BB-G80	1
10	O-Ring	SO-NB-G60	SO-NB-G85	SO-NB-G115	1
11	O-Ring	SO-NB-G30	SO-NB-P46	SO-NB-A231	1

List of Seal kits

Pump Model Numbers	Seal Kit Number
PV2R12-※-※-REAA-43	KS-PV2R12-40
PV2R13-※-※-RAAA-43	KS-PV2R13-40
PV2R23-※-※-REAA-41	KS-PV2R23-40
PV2R33-※-※-RAAA-31	KS-PV2R33-40

Pump Model Numbers	Seal Kit Number
PV2R14-※-※-RAAA-33	KS-PV2R14-30
PV2R24-※-※-RAAA-31	KS-PV2R24-30
PV2R34-※-※-REAA-31	KS-PV2R34-30