



A Polyhydron Group Company

FOOT PUMP Model : FP-10

Ref. No. D 06565
Release 11 / 2022

ENGINEERING - 1 of 2

Description

Heavy duty construction with hardened and ground plunger.
Both Suction and delivery valves are replaceable.
Intended for supply of lubricating oil or pilot pressure.

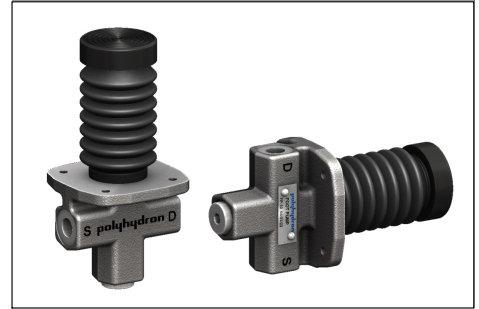

Unit dimensions

Dimensions in mm.

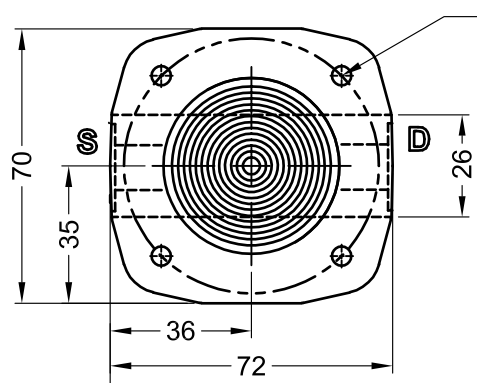
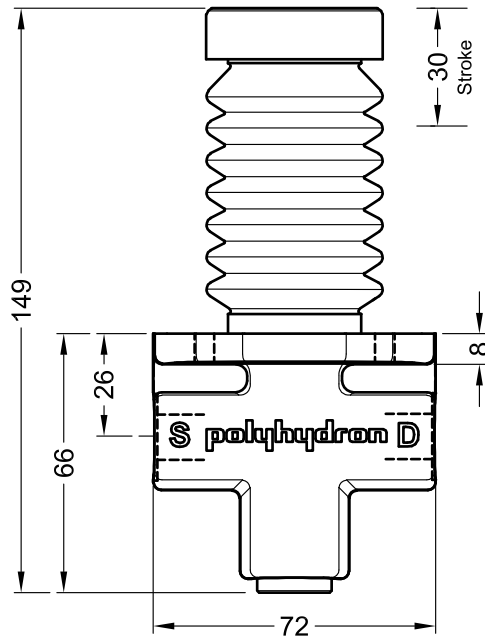
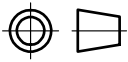

M6x1 tap, thru.
Equally spaced on 65 PCD.
(4 nos).

Hydraulic symbol

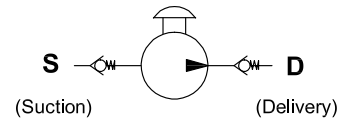

Port details

S	G 1/4 " BSP
D	G 1/4 " BSP

polyhydron pvt. ltd.

78-80, Machhe Industrial Estate,
Machhe, Belgaum - 590 014. INDIA.

Phone : +91-(0)831- 2411001
Fax : +91-(0)831- 2411002
E-mail : polyhydron@gmail.com
Website : www.polyhydron.com



Technical specifications

Construction	:	Plunger type
Flow direction	:	As per hydraulic symbol.
Displacement	:	2.35 cc / stroke.
Operating Pressure	:	Max 35 bar.
Operating force at 25 bar	:	250 N.
Operating force at 35 bar	:	330 N.
Maximum Suction pressure	:	100 mm of Hg .
Hydraulic medium	:	Mineral oil.
Viscosity range	:	10 cSt to 380 cSt.
Fluid temperature range	:	-10°C to +80°C.
Fluid cleanliness requirement	:	ISO 4406 20/18/15 or better.
Mass (approx)	:	0.9 kg Approx.

Ordering code

