



COVER WITH BUILT IN SHUTTLE VALVE

Model : CVC*S

Ref. No. D 03424
Release 12 / 2016

ENGINEERING - 1 of 2

A Polyhydron Group Company

Description

The Covers **CVC*S** are designed to hold Polyhydron make 2 port slip-in cartridge valves model **CV***** in the cavities machined as per ISO 7368 . It also meant to connect port C of the Cartridge to one of the two pressure sources, brought to its port X and port Z1 . Automatic selection of higher source pressure and isolation of these pressures from one another is done by the built in Shuttle valve in the cover.

Application of pressures at port C isolates port A of the cartridge from its port B.

To open the passage in the cartridge, it is essential to depresssuzize both the input sources provide to the cover.

The resultant pressure source acting on the port C is also available at port Z2 provided on the cover.

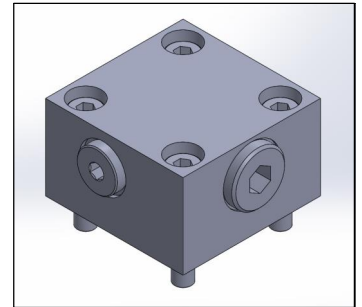

Section

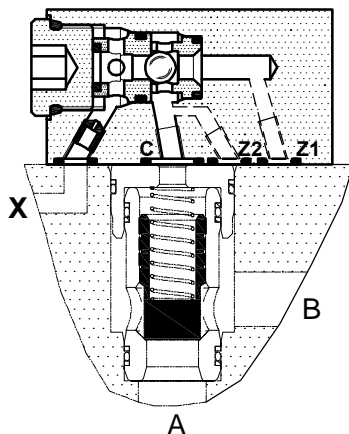

Hydraulic symbol

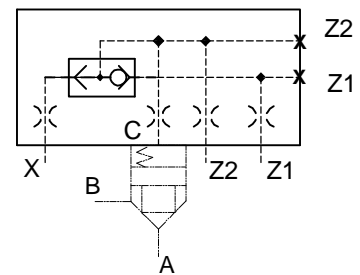

Technical specifications

Mounting interface	:	As per ISO 7368
Working pressure	:	350 bar.
Hydraulic medium	:	Mineral oil.
Temperature range	:	-20°C to + 80°C.
Viscosity range	:	10 cSt to 380 cSt.
Fluid cleanliness required	:	ISO 4406 20/18/15 or better.

polyhydron pvt. ltd.

78-80, Machhe Industrial Estate,
Machhe, Belgaum - 590 014. INDIA.

Phone : +91-(0)831- 2411001
Fax : +91-(0)831- 2411002
E-mail : polyhydron@gmail.com
Website : www.polyhydron.com



Unit dimensions

Dimensions in mm.

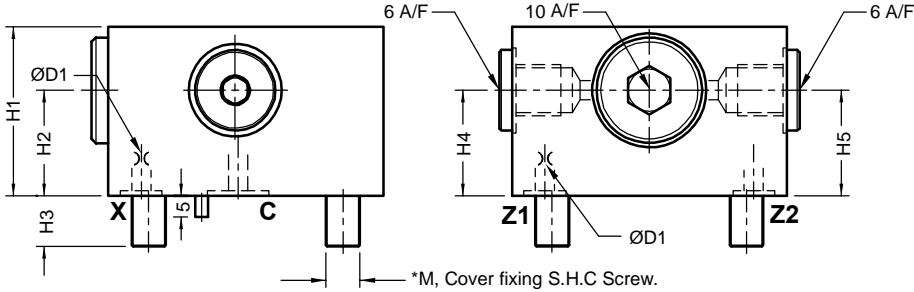
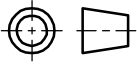

Note:

Cover fixing S.H.C Screws are **OUT OF SCOPE OF SUPPLY.**

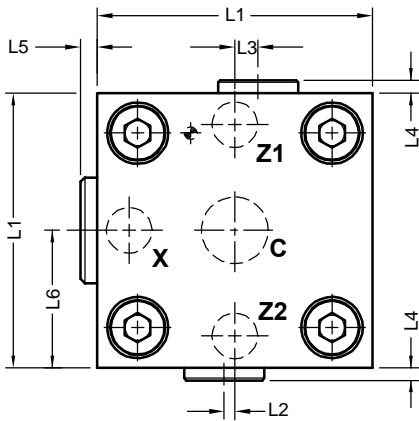

Cover mounting interface as per ISO 7368.

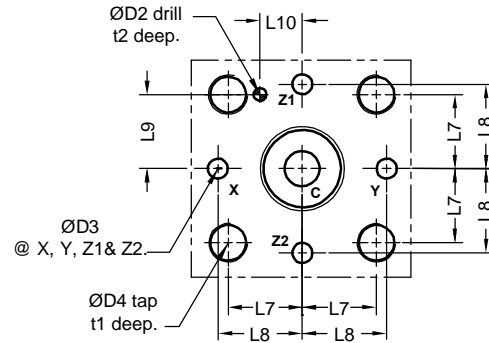

Size	Mass Kg. approx	L1	L2	L3	L4	L5	L6	L7	L8	L9	L10	ØD1	ØD2	ØD3 max	ØD4	t1	t2	H1	H2	H3	H4	H5	*M. 4 nos. Cover fixing S.H.C. Screw (Class 12.9)	Tightening Torque.
16	1.5	65	2.5	5.5	3	4	32.5	23	25	23	10.5	1	4	4	M8	14	10	40	25	12	25	25	M8 x 40 Long	39 Nm
25	2.5	85	6.0	6.0	3	2	42.5	29	33	29	16	1	6	6	M12	20	10	40	25	18	25	25	M12 x 45 Long	135 Nm
32	4.3	102	8.0	0.0	4	4	51	35	41	35	17	1.2	6	8	M16	26	10	50	30	24	30	25	M16 x 55 Long	330 Nm
40	7.5	125	0.0	0.0	4	0	62.5	42.5	50	42.5	23	1.2	6	10	M20	33	10	60	30	30	30	30	M20 x 70 Long	650 Nm

Ordering code

