



The right connection
The right environment

Pressure Gauge Isolator Valve 1GIMS

Ref. No. H14651
Release: Sept 2020

ENGINEERING - 1 of 2

Description

Gauge Isolator valves, 1GIMS are meant for applications where a pressure gauge is connected to a pressure line and needs to be isolated when not in use.

These can be mounted on a hydraulic manifold.

These Isolator valves offer following advantages,

- Simple machining of the interface,
- Quick assembly,
- Ease of axial orientation of the Pressure gauge face for proper alignment.
- Compact and elegant assembly,
- Easy readability of the gauge.

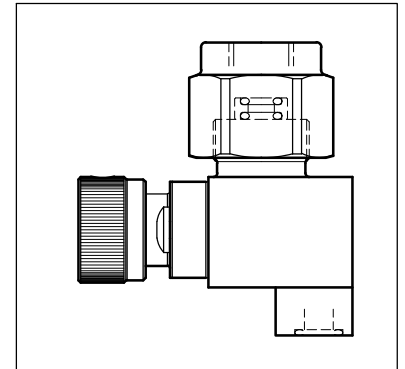

Section

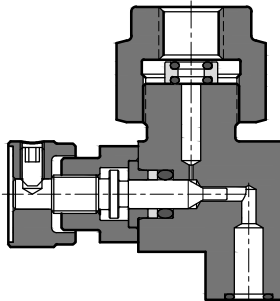

Hydraulic Symbol

Sub-plate Mounting, Model: 1GIMS

Unit Dimensions

Gauge Isolator Valve, Sub-plate Mounting, Model: 1GIMS

Dimensions in mm.

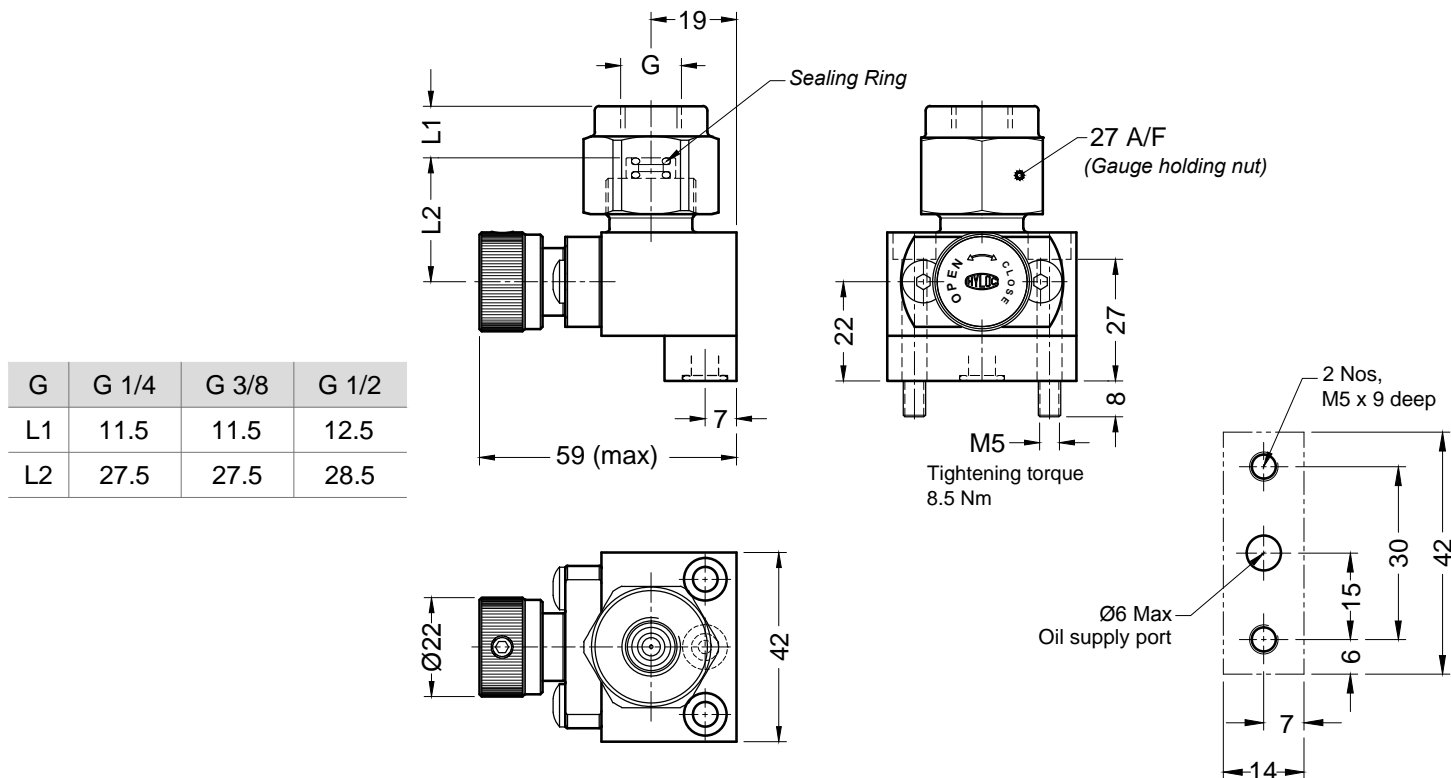

G	G 1/4	G 3/8	G 1/2
L1	11.5	11.5	12.5
L2	27.5	27.5	28.5

Mounting screws are not in scope of supply

Mounting Interface



The right connection
The right environment

Pressure Gauge Isolator Valve 1GIMS

Ref. No. H14651
Release: Sept 2020

ENGINEERING - 2 of 2

Technical Specifications

Construction	Seat type
Mounting	Sub-plate mounted
Interface standard	Factory standard.
Mounting position	Optional
Operating pressure	350 bar.
Hydraulic medium	Mineral oil.
Fluid temperature range	-20 °C to +70 °C.
Fluid cleanliness requirement	As per ISO 4406 20/18/15

Instructions for Pressure Gauge assembly

How to orient and tighten the gauge face to the desired position?

- Screw in the *Gauge holding Nut* onto the valve till its bottom face of it touches the face of the valve body.
- Insert the sealing ring provided with the valve, from the top of the nut.
- Screw in the gauge into the *Gauge Holding Nut* till its sealing face touches the sealing ring.
- Loosen the gauge (if required) by rotating it in anti-clockwise direction till the face of the gauge points towards desired position.
- Mount the Gauge Isolating Valve on to the sub-plate or panel.
- Rotate the Gauge Holding Nut by means of a spanner in anti-clockwise direction to tighten the gauge onto the sealing ring.
- While rotating the nut, hold the gauge to its proper orientation.

Ordering Code

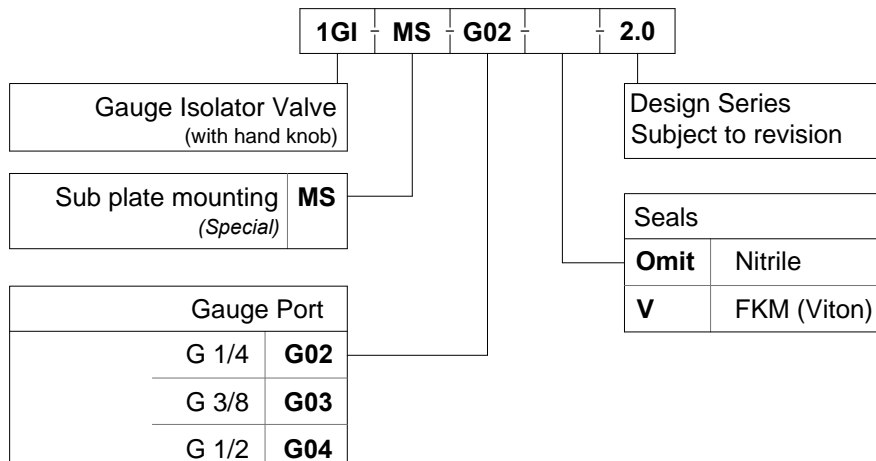

All rights reserved.
Subject to change without notice.
Due to continuous improvement in the design of the product, the actual product supplied may look different than shown above.